



USE CTRL+F FUNCTION TO FAST SEARCH

OVERVIEW

Buckeye Pads & Covers is pleased to offer the following dry cleaning pads and head plates for your customers' consideration. Offering our pads and head plates in varying combinations provides your customer with an option for every finishing situation. All of our dry cleaning pads are made with the highest quality foam ... foam that will produce maximum steam and vacuum porosity, while standing up to the day to day abuse of pressing garments. In addition, all of our pads are cut oversize to guarantee a better fit, preventing slippage and movement on the press, once installed.

Red Pro-Finish 861 (RPRO)

Add a splash of color to your finishing operation! The Red Pro-Finish Premium dry cleaning pad from Buckeye Pads & Covers will deliver you from those drab boring dry cleaning press pads currently on the market. Manufactured with Buckeye Pads & Covers's exclusive Pro-finish 861 material, the Red Pro Premium dry cleaning press pad will give long life and provide a *quality* finish on a wide variety of fabrics.

Tan Pro-Finish 861 (PRO)

Buckeye Pads & Covers's Pro-Finish 861 Press Pad (PRO) is designed with today's fabrics in mind. The PRO Pad will help eliminate those frustrating moire' patterns and seam impressions that appear on the micro-fiber polyester and rayon type garments. The exclusive PRO finish cover fabric is made of an industrial grade micro-fiber material that is soft and smooth to the touch. As a result, the smooth weave will not transfer marks on to the garments being finished. Because of its construction, the PRO 861 material will stretch and move with the garments being pressed, eliminating fabric distortion. For that professional finish, the Pro-Finish 861 is the dry cleaning pad of choice.

Black Master Finish Head Plate (BMFHP)

Buckeye Pads & Covers's Black Master Finish Head Plate is a totally Premium alternative to traditional fabric grid plates. The BMFHP does not show dirt, stains or wear signs. This head plate looks just like new from the first day you use it, to the last day. The construction of the BMFHP, along with the Black Nylon cover material, will produce a clean crisp finish on a wide range of fabrics, while giving extended service life. Looks Fantastic when paired with our Red Pro Finish Dry Cleaning pad.

White Master Finish Head Plate (MFHP)

The Buckeye Pads & Covers Master Finish Head Plate (MFHP) combines a perforated aluminum grid with a polyester outer cover. It also contains a layer of 20 Oz. Nylon Flannel, located between the grid and cover. The flannel aids in the dispersion of steam. The multi-layered construction allows for a firm press, while the flannel provides resiliency when finishing lightweight delicate garments.



CONTENTS

AJAX/ALLIANCE/AMERICAN.ACECO/MARTIN	
EQUIPMENT PICTURES	1
BUCK PADS/HEAD PLATES	2-3
PANTS TOPPERS AND SAF COVERS AND PADS	4-5
HOT HEAD AND SILK PRESSES	6
AMERICAN SUPREMA	7
APEX	7
BANNER MACHINERY	7
BARBANTI	8
BRUSKE	8
BUTLER	9
CAMPTEL	9
CINDY LOU	10
CISSELL	
EQUIPMENT PICTURES	11
BUCK PADS/HEAD PLATES	12-13
HOT HEAD AND SILK PRESSES	14
SLEEVE FINISHER	14
PANTS TOPPERS AND SAF COVERS AND PADS	14-16
COLMAC	17
DRAPERY PRESSES	17
DYNAMIC	18
EASTERN MACHINERY	18
EXCELSIOR	18
FIMAS	19
FINISHING IRONING BOARDS	20-22
FORENTA/FORSE	
EQUIPMENT PICTURES	23
BUCK PADS/HEAD PLATES	24-28
HOT HEAD AND SILK PRESSES	29
PANTS TOPPERS AND SAF COVERS AND PADS	30-32
CINDY LOU SLEEVE FINISHER	32
GOBUKSON	33
GOLDMAN	33
HI-STEAM	34
HOFFMAN/NEW YORKER/RHEEM	
EQUIPMENT PICTURES	35
BUCK PADS/HEAD PLATES	36-39
DOUBLE LAPEL PRESS	39
KORRECT KOLLAR	39
HOT HEAD AND SILK PRESSES	40
COLLAR FORMS AND SAF COVERS AND PADS	40
TENSIONING PANT TOPPER	41
HOT HEADS AND SILK PRESSES	42-43

CONTINUED ON NEXT PAGE



CONTENTS

HUEBSCH (GLOVER)	44
KWA SUNG	44
IOWA TECHNIQUES/CINDY LOU	44
ITSUMI	44
KONEIG	44
KUM SUNG	44
MCCALLISTER	45
MIRACLEAN	45
OFFSET PRESSES	46
PANTEX	47
PARIS	48
PONY/SIDI/CAMPTEL	
BUCK PADS/HEAD PLATES	48
PANTS TOPPERS AND SAF COVERS AND PADS	48
TENSIONING EQUIPMENT	48
PROSPERITY	49
PUFF IRONS	
COVERS/PADS	50
HEAD COVERS	51
RIMAR	52
ROTONDI	52
SAILSTAR	52
SANKOSHA	
EQUIPMENT PICTURES	53
BUCK PADS/HEAD PLATES	54
FORM FINISHER AND TENSIONING EQUIPMENT	54-56
PANTS TOPPER COVERS AND PADS	57
SIDI/PONY/CAMPTEL	57
STIRMATIC	58-59
TREVIL	59-60
UNIPRESS	
EQUIPMENT PICTURES	61
BUCK PADS/HEAD PLATES	62
HOT HEADS AND SILK PRESSES	63
PANTS TOPPERS AND SAF COVERS AND PADS	63-64
TENSIONING EQUIPMENT	65
VAPORPRESS	66
VEIT	67-68

DRY CLEANING



**AJAX/ALLIANCE/AMERICAN/ACECO/MARTIN
EQUIPMENT**



DC-45



DC-18



DCFB-446



DTM-3



SAF-3



AJAX/ALLIANCE/AMERICAN/ACECO/MARTIN BUCK PADS AND HEAD PLATES

MFG. MODEL NUMBER	BUCK SIZE	DESCRIPTION	BUCK PADS		HEAD PLATES		TEFLON GRID PLATE*
			PRO FINISH PAD/COVER	MASTER FINISH HEAD PLATE	WHITE	BLACK	
			TAN	RED			
DCRR	45 x 17 x 8 ¹ / ₂	Legger	PRO-844	RPRO-844	MFHP-53	BMFHP-53	TGP-53
CM-8 M-8 DC-18 (#282) DCB-18(#682) DCM-18 DC-19 DC-22	18 ¹ / ₂ x 9 ¹ / ₂	Mushroom	PRO-818	RPRO-818	MFHP-3	BMFHP-3	TGP-3
DCSC-40/R(#620)	38 ¹ / ₂ x 19 ¹ / ₂ x 9 ¹ / ₂	Automatic Sandwich Also takes Center Leaf (HS-552)	PRO-824	RPRO-824	MFHP-122	BMFHP-122	TGP-122
DCS-40-C (#303) DCSC-40-C(#720) 40-1A (#328)	39 x 21 x 11	Legger (2 required)	PRO-824	RPRO-824	N/R	N/R	N/R
CU-42 DC-42 SO-42	42 x 12 x 8	Utility	PRO-842	RPRO-842	MFHP-13	BMFHP-13	TGP-13
U-42	41 ¹ / ₂ x 12 x 7	Utility - Offset	SEE PAGE 44				
DCB-43/R(#691)	42 ¹ / ₄ x 11 ¹ / ₂ x 8	Utility	PRO-842	RPRO-842	MFHP-13	BMFHP-13	TGP-13
DC-43-C (#297) DCM-43 DC-44	43 x 12 ¹ / ₄ x 9 ¹ / ₂	Utility	PRO-891	RPRO-891	MFHP-81	BMFHP-81	TGP-81
AOU45/L(#304) AOU45/R(#404) AOUB45/L(#603) AOUB45/R(#604) DC 45/R (#298) DCB 45/R (#692) DCHB45/L(#499) DCHB45/R(#498) HOU-45-C SCU-45	44 ¹ / ₂ x 11 ¹ / ₂ x 8	Utility - Offset	PRO-845	RPRO-845	MFHP-17	BMFHP-17	TGP-17
ALU-46 DCM-46 DCS-46	45 x 12 x 8 46 x 19 x 8	Legger w/Cut-Out	PRO-850	RPRO-850	MFHP-25	BMFHP-25	TGP-25
	46 x 19 ¹ / ₂ x 8	Legger w/Square Large End (2 Required)	PRO-846	RPRO-846	N/A	N/A	N/A

* Model Number Required



**AJAX/ALLIANCE/AMERICAN/ACECO/MARTIN
BUCK PADS AND HEAD PLATES**

MFG. MODEL NUMBER	BUCK SIZE	DESCRIPTION	BUCK PADS		HEAD PLATES		TEFLON GRID PLATE*
			PRO FINISH PAD/COVER		MASTER FINISH HEAD PLATE		
			TAN	RED	WHITE	BLACK	
DC-51	49 ³ / ₄ x 19 ¹ / ₄ x 9	Legger	PRO-886	RPRO-886	MFHP-175	BMFHP-175	TGP-175
DC-446/R (#799) DCB-446/R (#699) DCF-446-C (#301) DCFB-446/R (#601) DCM-446 (#707)	46 x 20 x 8 ¹ / ₄ 46 x 19 x 8	Legger w/Cut-Out	PRO-850	RPRO-850	MFHP-25	BMFHP-25	TGP-25
DC-446-SE/R (#700) DCB-446-SE/R (#600) DCFB-446-SE/R (#602) DCF-446-SE-C (#302)	46 x 20 x 8 ¹ / ₄ 46 x 19 x 8	Legger w/Square Large End	PRO-846	RPRO-846	MFHP-40	BMFHP-40	TGP-40
DC-545 DCF-545	45 x 19 ³ / ₄ x 9	Legger w/Cut-Out	PRO-849	RPRO-849	MFHP-44	BMFHP-44	TGP-44
DC-642	42 x 12 x 8	Utility	PRO-842	RPRO-842	MFHP-13	BMFHP-13	TGP-13
DC-643-C (#252)	43 ³ / ₄ x 13 ¹ / ₂ x 10	Utility	PRO-891	RPRO-891	MFHP-80	BMFHP-80	TGP-80
AOU-645-C (#250) AOU-645/L (#753) AOU-645/R (#749) AOU-645-RC (#350) DC-645-C (#253) DC-645/R (#753)	45 x 12 x 8 44 ¹ / ₂ x 11 ¹ / ₂ x 8 45 x 12 x 8 43 ³ / ₄ x 13 ³ / ₄ x 9 ⁷ / ₈ 44 ¹ / ₂ x 11 ¹ / ₂ x 8	Utility	PRO-845	RPRO-845	MFHP-17	BMFHP-17	TGP-17
DC-646 DCF-646-C (#255) DCF-646/R (#755)	46 x 19 x 8	Legger w/Cut-Out	PRO-850	RPRO-850	MFHP-25	BMFHP-25	TGP-25
DC-646-SE-C (#251) DCF-646-SE/R (#754)	46 x 19 x 8 46 x 20 x 8 ¹ / ₄	Legger w/Square Large End	PRO-846	RPRO-846	MFHP-40	BMFHP-40	TGP-40

* Model Number Required



AJAX/ALLIANCE/AMERICAN/ACECO/MARTIN COVERS AND PADS FOR PANTS TOPPERS

MFG. MODEL NUMBER	CLAMP SIZE	DESCRIPTION	INDEX NUMBER		
ADT PT-25A	15 x 9	Cover & Pad Set for Pants Topper	953		
		Topper Clamp Cover/Pad (2 Required)	CPDB-958		
		Small Steam Boot (1 required)	1442		
		Large Steam Boot (2 required)	1443		
APT	15 x 7	Cover & Pad Set for Pants Topper	1080		
		Cover Only - A20742	931		
		Foam Pad Only	930		
		Topper Clamp Cover/Pad (2 Required)	CPDB-928		
		TEXSTEEL Steel Base Pad (Diffuser)	TS-930		
		FLAN-O-WOOL Metal Flannel Pad	FOW-930		
DT (PC343) DT-C (PC337) DTF (PC345) DTF-AA DTF-CA DTF-V (PC346) DTV (PC344) DTV-C (PC338) DTV-CA	15 x 7	Cover & Pad Set for Pants Topper	1080		
		Cover Only - A20742	931		
		Foam Pad Only	930		
		Topper Clamp Cover/Pad (2 Required)	CPDB-928		
		TEXSTEEL Steel Base Pad (Diffuser)	TS-930		
		FLAN-O-WOOL Metal Flannel Pad	FOW-930		
		DTM (PC841)	15 x 7	Cover & Pad Set for Pants Topper	953
				Topper Clamp Cover/Pad (2 Required)	CPDB-958
				Small Steam Boot (1 required)	1442
		DTF-BA	15 x 7	Cover only for Pants Topper - A24554	929
				Foam Pad Only	930
Topper Clamp Cover/Pad (2 Required)	CPDB-928				
TEXSTEEL Steel Base Pad (Diffuser)	TS-930				
FLAN-O-WOOL Metal Flannel Pad	FOW-930				
FAPT	15 x 7	Cover & Pad Set for Pants Topper	1080		
		Cover Only - A20742	931		
		Foam Pad Only	930		
		Topper Clamp Cover/Pad (2 Required)	CPDB-928		
		TEXSTEEL Steel Base Pad (Diffuser)	TS-930		
		FLAN-O-WOOL Metal Flannel Pad	FOW-930		



DTM



TS-930 — TEXSTEEL
STEEL BASE PAD



COVER AND PADS SET
FOR PANTS TOPPER

DRY CLEANING



AJAX/ALLIANCE/AMERICAN/ACECO/MARTIN COVERS AND PADS FOR STEAM AIR FINISHERS

MFG. MODEL NUMBER	CLAMP SIZE	DESCRIPTION	INDEX NUMBER
HU-10		STEAM AIR FINISHER SET	974
		Set contains:	
		Steam Air Finisher Cover	973
		Vest	976
		Moisture Sleeve	975
SAF-1 SAF-2 SAF-3 (PC390)		STEAM AIR FINISHER SET	974
		Set contains:	
		Steam Air Finisher Cover	973
		Vest	976
		Moisture Sleeve	975
	4 x 33	Front Clamp Cover/Pad	916
	4 x 24	Rear Clamp Cover/Pad	924
SAF-4 (PC840)		Steam Air Finisher Cover (No Cables - Solid Top)	1449
		Steam Air Finisher Cover (Net Top)	1457
	4 x 36	Front Clamp Cover/Pad	956
SAF-5		Universal Fast Fit Cover (No Cables)	945
		Steam Air Finisher Cover (w/Cables)	946
	4 x 36	Front Clamp Cover/Pad	956
	4 x 25 1/2	Rear Clamp Cover/Pad	927



SAF-3



**AJAX/ALLIANCE/AMERICAN/ACECO/MARTIN
HOT HEAD AND SILK PRESSES**

MFG.

MODEL

NUMBER

BUCK SIZE

DESCRIPTION

DCH-18 DCHB-18	18 ¹ / ₂ x 9 ¹ / ₄	Mushroom - Hot Head	SEE PAGE 42
DCH-45 DCHB-45 HOU 45/C (#405) HOU 45/L (#405) HOUB 45/L (#605)	44 ¹ / ₂ x 11 ¹ / ₂ x 8	Utility - Hot Head	SEE PAGE 42
DCH-446 DCHB-446 DCHF-446 DCHFB-446	46 x 20 x 8 ¹ / ₄	Legger - Hot Head	SEE PAGE 42



DRY CLEANING



AMERICAN SUPREMA BUCK PADS AND HEAD PLATES

MFG. MODEL NUMBER	BUCK SIZE	DESCRIPTION	BUCK PADS		HEAD PLATES		TEFLON GRID PLATE*
			PRO FINISH PAD/COVER		MASTER FINISH HEAD PLATE		
			TAN	RED	WHITE	BLACK	
CM-280-S	46 x 13 ¹ / ₄ x 10	Utility	PRO-883	RPRO-883	MFHP-129	BMFHP-129	TGP-129
CML-280-S	45 ¹ / ₂ x 17 ¹ / ₄ x 13 ¹ / ₄	Legger w/Cut-Out/ Square End	PRO-899	RPRO-899	MFHP-163	BMFHP-163	TGP-163
CMUL-282-S	45 ¹ / ₂ x 17 ¹ / ₄ x 10	Utility/Legger w/Cut-Out/ Round End	PRO-1276	RPRO-1276	MFHP-159	BMFHP-159	TGP-159

* Model Number Required

APEX COVER AND PADS FOR PANTS TOPPERS

MFG. MODEL NUMBER	CLAMP SIZE	DESCRIPTION	INDEX NUMBER
55P	N/A	Cover & Pad Set for Pants Topper	2552

BANNER MACHINERY/CINDY LOU COVER AND PAD FOR SLEEVE FINISHER

MFG. MODEL NUMBER	DESCRIPTION
2000	See Page DC10



**BARBANTI
TENSIONING EQUIPMENT**

MFG. MODEL NUMBER	DESCRIPTION	INDEX NUMBER
451 SHIRT FINISHER	Cover w/skirt	1995
	28" Clamp Cover/Pad	2012
	32" Clamp Cover/Pad	1997
	36" Clamp Cover/Pad	1999
	41" Clamp Cover/Pad	2008
	Cuff Clamp - Foam Cylinder Shaped Pads (Set of 4)	SET 2035
	Collar Support Cover	2038
	Side Clamp Cover - Fixed (2 Required)	WA-2118
	Side Clamp Cover w/Foam - Mobile (2 Required)	WAFM-2152
	Rear Clamp Cover w/Foam - Mobile	WAFM-2153
	Rear Clamp Cover - Fixed	WA-2171
	Silicone Pad for Cuff Clamp Stopper (Set of 2)	SET 2172
	1/4" Silicone Clamp Pad (4 Required) - wires to Cuff Clamp	BS-2215
465 510 SHIRT FINISHER	Shoulder Buck Cover	PK-2080
	Front Lapel Clamp Cover	2082
	Extension Bag - Lower Body	2084
	Front and Rear Clamp Cover (2 Required)	2086
483 SHIRT FINISHER	Cover	2565
	30 Oz. Flannel Pad	FB-2563
	Rear Clamp Cover/Pad	PKFB-1102
	Side Clamp Cover (Requires 2)	WA-1104
	Clamp Cover/Pad (Requires 2)	WAFB-1101
	Front Clamp Cover/Pad	WAJU-2622
	Long Sleeve Silicone Pad Cuff Clamp Stopper (Requires 2)	2624
	Short Sleeve Cuff Cover (Requires 4)	WK-2626
	Top Holder Clamp Cover (Requires 2)	WK-2628
Rear Clamp Cover w/Sensor	WK-2564	

**BRUSKE
MULTI-FORM FINISHERS**

DESCRIPTION	INDEX NUMBER
Multi-Finisher Cover - Short - 41"	2158
Multi-Finisher Cover - Long - 54"	2164

DRY CLEANING



BUTLER BUCK PADS AND HEAD PLATES

MFG. MODEL NUMBER	BUCK SIZE	DESCRIPTION	BUCK PADS		HEAD PLATES		TEFLON GRID PLATE*
			PRO FINISH PAD/COVER		MASTER FINISH HEAD PLATE		
			TAN	RED	WHITE	BLACK	
D-18-2A P-18	18 x 9	Mushroom	PRO-818	RPRO-818	MFHP-3	BMFHP-3	TGP-3
P-40	40 x 12 x 8	Utility	PRO-840	RPRO-840	MFHP-21	BMFHP-21	TGP-21
P-41-2A	42 x 12 x 8	Utility	PRO-842	RPRO-842	MFHP-10	BMFHP-10	TGP-10
P-45	45 x 13 x 9	Utility	PRO-845	RPRO-845	MFHP-67	BMFHP-67	TGP-67
M-48	40 x 12 x 8	Utility	PRO-840	RPRO-840	MFHP-21	BMFHP-21	TGP-21
211-EK	18 x 9	Mushroom	PRO-818	RPRO-818	MFHP-3	BMFHP-3	TGP-3
211-1M	40 x 12 x 8	Utility	PRO-840	RPRO-840	MFHP-21	BMFHP-21	TGP-21
211-45	45 x 13 x 9	Utility	PRO-845	RPRO-845	MFHP-67	BMFHP-67	TGP-67

* Model Number Required

CAMPTEL BUCK PADS AND HEAD PADS

MFG. MODEL NUMBER	BUCK SIZE	DESCRIPTION	BUCK PADS		HEAD PADS	
			BUCK COVER	BUCK PADS	HEAD COVER	HEAD PADS
452V	47 x 14 x 9	Utility	PK-2130	SET-2121 (Set of 3*)	PK-2130	SET-2119 (Set of 2**)

*Set consists of 1 each 20 oz., 30 oz., and 50 oz. pad

**Set consists of 1 each 20 oz. and 30 oz. pad

CAMPTEL STEAM AIR FINISHER

MFG. MODEL NUMBER	DESCRIPTION	INDEX NUMBER
30V 451V	Steam Air Finisher Cover	2120



**CINDY LOU/FORENTA
COVER AND PAD FOR SLEEVE FINISHER**

MFG. MODEL NUMBER	DESCRIPTION	INDEX NUMBER
80SF	Cover - Regular size	1220
81SF	Cover - Oversized	1880
	Nomex Pipe Pad (Fits both regular and oversized)	JUH-1280
	Belt Ring (Fits both regular and oversized)	1222

**CINDY LOU/BANNER MACHINERY
COVER AND PAD FOR SLEEVE FINISHER**

MFG. MODEL NUMBER	DESCRIPTION	INDEX NUMBER
2000	Cover - REGULAR (8" diameter)	1820
	Cover - OVERSIZED (13" diameter)	1939
	Pipe Pad (Fits both regular and oversized)	HB-1939
	Belt Ring (Oversized)	1942
	Belt Ring (Small)	1828

**CINDY LOU/IOWA TECHNIQUES
COVER AND PAD FOR SLEEVE FINISHER**

MFG. MODEL NUMBER	DESCRIPTION	INDEX NUMBER
Sleeve Master	Cover	1875
	Pipe Pad	HB-1875
	Belt Ring	1842

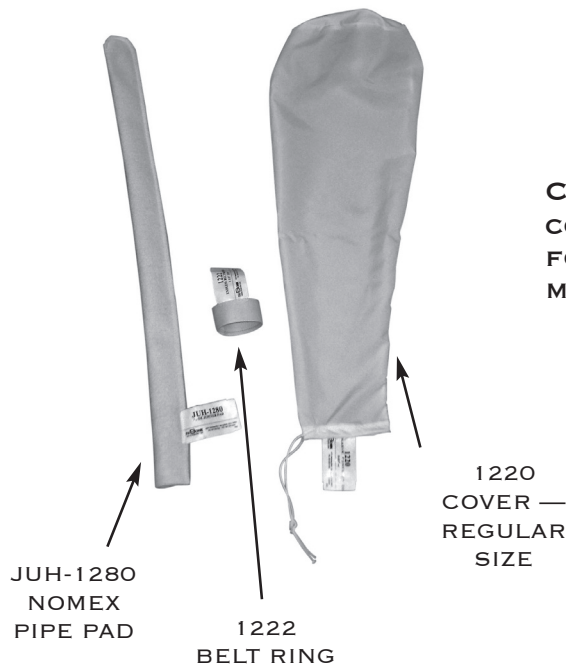

**CINDY LOU/FORENTA
COVER, PAD, AND BELT RING
FOR SLEEVE FINISHER
MODELS 80SF & 81SF**



**CISSELL
EQUIPMENT**



PUFF IRON-3



**PANT TOPPER
PT-25-B**



52" IRONING BOARD



MS-CISSELL



MR CISSELL



SLEEVE FINISHER



CISSELL BUCK PADS AND HEAD PLATES

MFG. MODEL NUMBER	BUCK SIZE	DESCRIPTION	BUCK PADS		HEAD PLATES		TEFLON GRID PLATE*
			PRO FINISH PAD/COVER		MASTER FINISH HEAD PLATE		
			TAN	RED	WHITE	BLACK	
LOPZ OPB OPC OPL	41 x 12 x 9	Utility - Offset	SEE PAGE 44				
AMT-15	15 x 9	Mushroom	PRO-815	RPRO-815	MFHP-99	BMFHP-99	TGP-99
AMT-19 AMT-19-C MMT-19	19 x 10	Mushroom	PRO-818	RPRO-818	MFHP-171	BMFHP-171	TGP-171
ATT-24	23 x 10 ^{1/2} x 8	Topper	PRO-822	RPRO-822	MFHP-9	BMFHP-9	TGP-9
CI-41-ADX AU-42 AU-42C AUR-42 AUR-42C MU-42 PAU-42 PMU-42	41 x 13 x 9	Utility	PRO-840	RPRO-840	MFHP-21	BMFHP-21	TGP-21
AL-45 AOL-45	43 x 18 x 11	Legger w/Cut-Out	PRO-805	RPRO-805	MFHP-121	BMFHP-121	TGP-121
AU-45 AU-45-C AUR-45 AUR-45C CI-45-ADX CU-45-70 MU-45 MU-45C PAU-45 PMU-45 SCPAU-45	45 x 12 x 9	Utility	PRO-845	RPRO-845	MFHP-54	BMFHP-54	TGP-54
AL-45-C AOL-45-C PAOL-45 SPAOL-45	45 x 20 x 9	Legger w/Cut-Out	PRO-849	RPRO-849	MFHP-180	BMFHP-180	TGP-180
AOL-45-K	45 x 12 x 9	Legger w/Cut-Out	PRO-1559 (PR-641)	RPRO-1559	MFHP-220 (PR-642)	BMFHP-220	TGP-220
AU-45-K MU-45-K <i>(44" VERSION)</i>	44 x 12 x 9	Utility	PRO-1564 (PR-645)	RPRO-1564	MFHP-209 (PR-646)	BMFHP-209	TGP-209

* Model Number Required



DRY CLEANING



CISSELL BUCK PADS AND HEAD PLATES

MFG. MODEL NUMBER	BUCK SIZE	DESCRIPTION	BUCK PADS		HEAD PLATES		TEFLON GRID PLATE*
			PRO FINISH PAD/COVER		MASTER FINISH HEAD PLATE		
			TAN	RED	WHITE	BLACK	
AU-45-K MU-45-K <i>(45" VERSION)</i>	45 x 12 x 9	Utility	PRO-1560 (PR-695)	RPRO-1560	MFHP-207 (PR-696)	BMFHP-207	TGP-207
AU-47 AU-47C AUR-47 AUR-47C MU-47 MU-47C	46 x 14 x 9	Utility	PRO-847	RPRO-847	MFHP-22	BMFHP-22	TGP-22
UR-47 URA-47 (770) (Self Contained)	47 x 14 x 8 1/2	Utility	PRO-1256	RPRO-1256	MFHP-148	BMFHP-148	TGP-148
LR-47 LRA-47 (770) (Self Contained)	48 x 21 x 10	Legger w/Cut-Out	PRO-1257	RPRO-1257	MFHP-157	BMFHP-157	TGP-157
AOL-48	48 x 19 x 12	Legger w/Cut-Out	PRO-848	RPRO-848	MFHP-64	BMFHP-64	TGP-64
AU-52 MU-52 PAU-52 PMU-52	51 x 17 x 11	Utility	PRO-851	RPRO-851	MFHP-56	BMFHP-56	TGP-56
AMT-193	19 x 10	Mushroom	PRO-818	RPRO-818	MFHP-171	BMFHP-171	TGP-171
ATT-243	23 x 11 x 8	Topper	PRO-822	RPRO-822	MFHP-9	BMFHP-9	TGP-9
ABP-439	42 x 19 1/4	Rectangular Legger w/Cut-Out	PRO-1525	RPRO-1525	MFHP-74	BMFHP-74	TGP-74
444-EDX	43 x 18 x 11	Legger w/Cut-Out	PRO-805	RPRO-805	MFHP-121	BMFHP-121	TGP-121
AOL-445	45 x 20 x 9	Legger w/Cut-Out	PRO-1266	RPRO-1266	MFHP-155	BMFHP-155	TGP-155
UR-471 URA-471	47 x 14 x 8 1/2	Utility	PRO-1256	RPRO-1256	MFHP-148	BMFHP-148	TGP-148
AMT-1934	19 x 10	Mushroom	PRO-818	RPRO-818	MFHP-171	BMFHP-171	TGP-171
ATT-2434	23 x 10 1/2 x 8	Topper	PRO-822	RPRO-822	MFHP-9	BMFHP-9	TGP-9

* Model Number Required

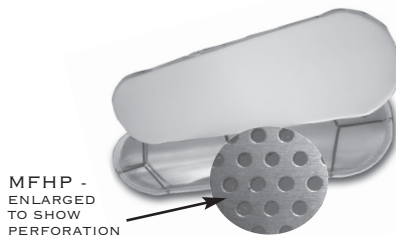

LEGGER W/CUT-OUT



MFHP - W/CUT-OUT



**CISSELL
HOT HEAD AND SILK PRESSES**

MFG. MODEL NUMBER	BUCK SIZE	DESCRIPTION	
AUH-42 AURH-42 MUH-42	41 x 13 x 9	Utility - Silk	SEE PAGE 42
AUH-45 AURH-45 MUH-45	45 x 12 x 9	Utility - Silk	SEE PAGE 42

**CISSELL
SLEEVE FINISHER**

MFG. MODEL NUMBER	DESCRIPTION	INDEX NUMBER
SLEEVE FINISHER <i>VERTICAL & HORIZONTAL</i>	Cover Bag with Ring - SF25 Nylon Inner Bag - SF24 DF Cotton Pipe Pad - SF26	1219 1238 DFC-1237



**CISSELL
COVERS AND PADS FOR PANTS TOPPERS**

MFG. MODEL NUMBER	CLAMP SIZE	DESCRIPTION	INDEX NUMBER
A PT-25-A	15 x 9	Cover & Pad Set for Pants Topper Topper Clamp Cover/Pad (2 Required) Small Steam Boot (1 required) Large Steam Boot (2 required)	953 CPDB-958 1442 1443
B PT-25-B	15 x 9 5 1/2 x 2	Cover & Pad Set for Pants Topper Topper Clamp Cover/Pad (2 required) Fly Clamp Cover/Pad Small Moisture Barrier (1 required) Large Moisture Barrier (2 required)	1246 CPDB-958 HTD-1290 1442 1443



**CISSELL
COVERS AND PADS FOR STEAM AIR FINISHERS**

MFG. MODEL NUMBER	CLAMP SIZE	DESCRIPTION	INDEX NUMBER
AF-1		Aire Form Steam Air Finisher Cover (No Cables) - AF114	940
	4 x 36	Front Clamp Cover/Pad	956
	4 x 25 ¹ / ₂	Rear Clamp Cover/Pad	927
CF-100 (MR. CISSELL)		Universal Fast Fit Cover (No Cables)	945
		Steam Air Finisher Cover (w/Cables) - FD10 (52")	946*
		Steam Air Finisher Cover (w/Cables) - FG10 (58")	949*
	4 x 36	Front Clamp Cover/Pad	956
	4 x 25 ¹ / ₂	Rear Clamp Cover/Pad	927
CF-600 (MS. CISSELL)		Steam Air Finisher Cover (No Cables - Solid Top)	1449*
		Steam Air Finisher Cover (Net Top)	1457
	4 x 36	Front Clamp Cover/Pad	956
	4 x 25 ¹ / ₂	Rear Clamp Cover/Pad	927
CF-600 (SENSI-FORM)		Universal Fast Fit Cover (No Cables)	945
		Steam Air Finisher Cover (w/Cables)	1437*
	4 x 36	Front Clamp Cover/Pad	956
FCAF		Aire Form Steam Air Finisher Cover (No Cables) - AF114	940
		Steam Air Finisher Cover(w/Cables) - FD10	946
	4 x 36	Front Clamp Cover/Pad	956
	4 x 25 ¹ / ₂	Rear Clamp Cover/Pad	927
FCCD		Universal Fast Fit Cover (No Cables)	945
		Steam Air Finisher Cover(w/Cables) - FD10	946
	4 x 36	Front Clamp Cover/Pad	956
	4 x 25 ¹ / ₂	Rear Clamp Cover/Pad	927
FCCG		Universal Fast Fit Cover (No Cables)	945
		Steam Air Finisher Cover(w/Cables) - FG10	949
	4 x 42	Front Clamp Cover/Pad	957
	4 x 31 ¹ / ₂	Rear Clamp Cover/Pad	922
FCFG		Universal Fast Fit Cover (No Cables)	945
		Genie Steam Air Finisher Cover (w/Cables) 56" (F817/F833/F806)	943*
	4 x 36	Front Clamp Cover/Pad	956
	4 x 25 ¹ / ₂	Rear Clamp Cover/Pad	927
FF		Universal Fast Fit Cover (No Cables)	945
		Steam Air Finisher Cover(w/Cables) - FA10	944
	4 x 33	Front Clamp Cover/Pad	916
	4 x 14	Rear Clamp Cover/Pad	955
FFA		Universal Fast Fit Cover (No Cables)	945
		Steam Air Finisher Cover(w/Cables) - FD10	946*
	4 x 33	Front Clamp Cover/Pad	916
	4 x 14	Rear Clamp Cover/Pad	955
FFAD FFCD		Universal Fast Fit Cover (No Cables)	945
		Steam Air Finisher Cover(w/Cables) - FD10	946
	4 x 36	Front Clamp Cover/Pad	956
	4 x 25 ¹ / ₂	Rear Clamp Cover/Pad	927

* See diagrams on page DC 16.



CISSELL COVERS AND PADS FOR STEAM AIR FINISHERS

MFG. MODEL NUMBER	CLAMP SIZE	DESCRIPTION	INDEX NUMBER
FFAG FFCG		Universal Fast Fit Cover - 52" (No Cables)	945
		Steam Air Finisher Cover(w/Cables) - FG10	949
	4 x 42	Front Clamp Cover/Pad	957
	4 x 31½	Rear Clamp Cover/Pad	922
FFL		Universal Fast Fit Cover - 52" (No Cables)	945
		Steam Air Finisher Cover(w/Cables) - F10L	944
	4 x 42	Front Clamp Cover/Pad	957
	4 x 31½	Rear Clamp Cover/Pad	922
FG-1 FG-2 FMFC		Genie Steam Air Finisher Cover (w/Cables) 56"	943
		(F817/F833/F806)	
	4 x 36	Front Clamp Cover/Pad	956
	4 x 25½	Rear Clamp Cover/Pad	927
MR. CISSELL (CF-100)		Universal Fast Fit Cover - 52" (No Cables)	945
		Steam Air Finisher Cover (w/Cables) - FD10 (52")	946
		Steam Air Finisher Cover (w/Cables) - FG10 (58")	949
	4 x 36	Front Clamp Cover/Pad	956
	4 x 25½	Rear Clamp Cover/Pad	927
MS. CISSELL (CF-600)		Steam Air Finisher Cover (No Cables - Solid Top)	1449
		Steam Air Finisher Cover (Net Top)	1457
	4 x 36	Front Clamp Cover/Pad	956
	4 x 25½	Rear Clamp Cover/Pad	927
SENSI-FORM (CF-600)		Universal Fast Fit Cover - 52" (No Cables)	945
		Steam Air Finisher Cover (w/Cables)	1437
	4 x 36	Front Clamp Cover/Pad	956
SUZIE II		Universal Fast Fit Cover - 52" (No Cables)	945
		Genie Steam Air Finisher Cover (w/Cables) 56"	943
		(F817/F833/F806)	
	4 x 36	Front Clamp Cover/Pad	956
	4 x 25½	Rear Clamp Cover/Pad	927
Most CISSELL SAF Models		Net Overbag	947
		Steam Air Finisher Cover - w/Net Top (No Cables) 52"	906
		Steam Air Finisher Cover - w/Net Top (No Cables) 56"	908



MR. CISSELL

52" **#946** W/CABLES
58" **#949** W/CABLES
USED FOR BLAZERS,
JACKETS, AND COATS
CABLES ON INSIDE



SUZIE II

52" **#943** W/CABLES
USED FOR SPORTS
JACKETS, SWEATERS,
AND DRESSES
CABLES ON OUTSIDE
WITH WEIGHTS



MS. CISSELL

53" **#1449** NO CABLES
USED FOR DRESSES AND
DELICATE GARMENTS
ALSO FITS THE **AJAX SAF-4**



SENSI-FORM

#1437 W/CABLES
USED FOR FULL
LENGTH GARMENTS
CORD LOCKS ON
OUTSIDE

DRY CLEANING



COLMAC COVERS AND PADS FOR PANT TOPPERS

MFG. MODEL NUMBER	DESCRIPTION	INDEX NUMBER
TOPCAT	Cover & Pad Set for Pants Topper	1843

DRAPERY PRESSES BUCK PADS

BUCK SIZE	PRO FINISH PAD/COVER	HI-SPUN ARAMID	50 OZ. BONN-E-BLUE PAD	TEXSTEEL STEEL BASE PAD*
20 x 52	PRO-242	HS-242	HB-242	TS-152
24 x 48	PRO-229	HS-229	HB-229	TS-274
24 x 60	PRO-278	HS-278	HB-278	TS-160
24 x 96	PRO-423	HS-423	HB-423	TS-603
29 x 90	PRO-420	HS-420	HB-420	TS-115
29 x 96	PRO-2178	HS-2178	HB-2178	TS-2178
29 x 110	PRO-427	HS-427	HB-427	TS-117
30 x 60	PRO-279	HS-279	HB-279	TS-277
30 x 72	PRO-363	HS-363	HB-363	TS-278
32 x 72	PRO-363	HS-363	HB-363	TS-336
FORENTA 24 x 60 6024VLFV 6024VLFV	PRO-1978	HS-1978	HB-1978	TS-1978

NOTE: IF YOUR DRAPERY PRESS USES TEXSTEEL, YOU SHOULD USE A HI-SPUN COVER AND 50 OZ. PAD.

*** SPECIFY BARE BUCK
or OVER SPRINGS**



**DYNAMIC
BUCK PADS AND HEAD PLATES**

MFG. MODEL NUMBER	BUCK SIZE	DESCRIPTION	BUCK PADS		HEAD PLATES		TEFLON GRID PLATE*
			PRO FINISH PAD/COVER		MASTER FINISH HEAD PLATE		
			TAN	RED	WHITE	BLACK	
DL-280-B	47 x 18 x 13	Legger w/cut-out Square End	PRO-899	RPRO-899	MFHP-163	BMFHP-163	TGP-163
DU-280-B	47 x 15 x 11½	Utility	PRO-883	RPRO-883	MFHP-129	BMFHP-129	TGP-129

* Model Number Required

**EASTERN MACHINERY
BUCK PADS AND HEAD PLATES**

MFG. MODEL NUMBER	BUCK SIZE	DESCRIPTION	BUCK PADS		HEAD PLATES		TEFLON GRID PLATE*
			PRO FINISH PAD/COVER		MASTER FINISH HEAD PLATE		
			TAN	RED	WHITE	BLACK	
SW-42	42 x 12 x 9	Utility	PRO-1770	RPRO-1770	MFHP-237	BMFHP-237	TGP-237
SW-45	43¾ x 18 x 9	Legger w/cut-out	PRO-1768	RPRO-1768	MFHP-225	BMFHP-225	TGP-225

* Model Number Required

**EXCELSIOR
BUCK PAD**

MFG. MODEL NUMBER	BUCK SIZE	DESCRIPTION	INDEX NUMBER
300	42 x 12 x 8	Utility - Offset	SEE PAGE 46



**FIMAS
COVERS AND PADS FOR PANTS TOPPERS**

MFG. MODEL NUMBER	DESCRIPTION	INDEX NUMBER
370	Pants Topper Cover	1950
375	Expander Cover 4" x 8" - (2 Required)	WK-2043
380	OR Expander Cover/Pad 7½" x 9" - (2 Required)	WKDB-2046

**FIMAS
COVER FOR STEAM AIR FINISHER**

MFG. MODEL NUMBER	DESCRIPTION	INDEX NUMBER
310	Cover (Sleeveless)	1872
311	Cover (with Sleeves)	1852
370	Cover (Rotating Buck) May include Model 370 Pants Topper listed above	1987

**FIMAS
SHIRT TENSIONING EQUIPMENT**

MFG. MODEL NUMBER	CLAMP SIZE	DESCRIPTION	INDEX NUMBER
376	5 x 5	Shoulder Buck Cover	PK-2080
		Front Lapel Clamp Cover	2082
		Extension Bag for Lower Body	2084
		Front and Rear Clamp Cover - (2 Required)	2086
379	13 x 7½ x 6½	Shoulder Buck Cover	PK-2080
		Extension Bag for Lower Body	2640
		Front and Rear Clamp Cover (Requires 2)	2086
386	4 x 32	Cover	1099
		30 oz. Bonn-E-Blue Flannel Pad	FB-1096
		Side Clamp Cover - (2 Required)	WA-1104
		Front Clamp Cover/Pad - (2 Required)	WAFB-1101
		Front Blade Cover	WAJU-1103
		Rear Clamp Cover/Pad	PKFB-1102
		Cuff Clamp Cover w/Silicone Foam Pads - (4 Required)	FM-1108



FINISHING - IRONING BOARDS COVERS AND PADS

MODEL #	BOARD SIZE	COMBO PAD/COVER	HI-SPUN ARAMID COVER	PRO KNIT COVER	PAD
BARBANTI PND5000B	50 X 20 X 7	N/A	HS-1436	PK-1436	HB-1436
BISHOP PUFF-N-IRON	39 X 13 1/2 X 7 1/4	N/A	HS-724	N/A	HB-724
BISHOP SWING ARM	20 X 12 X 10	N/A	HS-1381	N/A	HB-1381
BMSTIRO 1501	51 X 21 1/2 X 14	PBFM-2019	N/A	N/A	N/A
BMSTIRO 1502	54 X 21 1/2 X 14	PBFM-2020	N/A	N/A	N/A
BRUSKE FM-2E	60 X 23 X 14		HS-1956	PK-1956	HB-1956
CISSELL A & C PLEAT SETTER FBC41 SMALL PLEAT SETTER FB152 LARGE	46 X 13 X 8 1/2	N/A CPDB-984 CPDB-991	HS-717	PK-717	HB-717
CISSELL GMA-5	54 X 14 X 6	N/A	HS-1616	N/A	HB-1616
CISSELL GMA-6	54 X 22 1/2 X 8 1/2	N/A	HS-1608	N/A	HB-1608
CISSELL 38" METAL	39 X 12 X 8	N/A	HS-693	N/A	HB-693
CISSELL 52" METAL W/46" IRONING SURFACE	45 X 15 X 10	N/A	HS-504	N/A	HB-504
CISSELL S-H 52"	46 X 18 X 6 1/2	N/A	HS-1032	N/A	HB-1032
CISSELL WOOD TOP W/46" IRONING SURFACE	46 X 13 X 8 1/2	N/A	HS-504	N/A	HB-504
ELCO	42 1/2 X 14 1/2 X 8	N/A	HS-650	N/A	HB-650
FIMAS 102/103	60 X 23 X 14	N/A	HS-1956	PK-1956	FM-1956
FIMAS 150	43 X 14 X 11	N/A	HS-2332	N/A	HB-2332
FIMAS 159	45 X 16 X 9 1/2	N/A	HS-1552	N/A	HB-1552
FIMAS 168	47 X 19 X 14	N/A	N/A	PK-2221	HB-2221
FIMAS 174.22	37 1/4 X 71	N/A	HS-1643	PK-1643	HB-1643
FIMAS 307	50 1/2 X 19 1/2 X 9	N/A	N/A	PK-2058	FB-2058
FORENTA 8TBE/8TBS	38 x 12 1/2 x 8 1/2	N/A	HS-1459	N/A	HB-1459
FORENTA 46 SVB PLEAT SETTER SMALL PLEAT SETTER LARGE	44 1/2 X 12 3/4 X 8 3/4	BAFB-2060 BNDB-2063 BNDB-2065	N/A N/A N/A	N/A N/A N/A	N/A N/A N/A
FORENTA 46SVBA	44 1/2 X 12 3/4 X 8 3/4	PRO-836	N/A	N/A	N/A
GLOVER VF	43 1/4 X 15 1/2 X 8 1/2	N/A	HS-1308	N/A	HB-1308
HI STEAM/NAOMATO FB-8	43 X 15 X 9	N/A	HS-1308	N/A	HB-1308
HI-STEAM/NAOMATO FB-10	45 X 12 X 7	N/A	HS-1270	N/A	HB-1270
HI-STEAM/NAOMATO FB-10-S	40 X 12 X 7	N/A	HS-1615	N/A	HB-1615
HI-STEAM/NAOMATO FB-10-W	32 X 16	NA	HS-1614	N/A	HB-1614



**FINISHING - IRONING BOARDS
COVERS AND PADS**

MODEL #	BOARD SIZE	COMBO PAD/COVER	HI-SPUN ARAMID COVER	PRO KNIT COVER	PAD
HI-STEAM/NAOMATO FB-85-W	35 1/2 X 18	N/A	HS-1618	N/A	HB-1618
HI-STEAM/NAOMATO FB-115/ FB-115 PH	47 X 14 X 7	N/A	HS-1612	N/A	HB-1612
HI-STEAM NAOMATO FB-180S/SV	72 X 36	N/A	HS-1619	N/A	HB-1619
HI-STEAM/NAOMATO FB-700	48 X 26	N/A	HS-1613	N/A	HB-1613
HI-STEAM/NAOMATO FB-870-X	40 1/2 X 15 1/2 X 9	N/A	HS-1438	N/A	HB-1438
HI-STEAM/NAOMATO FBZ-120 AND PND-120	48 X 26	N/A	HS-1645	N/A	HB-1645
HI-STEAM/NAOMATO PND-25R	48 X 20	N/A	HS-1347	N/A	HB-1347
HI-STEAM/NAOMATO PND-150U/ PND-150UV/PND 150UZ PND-1000 PND-2000	44 X 15 X 9	N/A	HS-1277	PK-1277	HB-1277
HI-STEAM PND-3000	48 X 17 X 10	N/A	HS-2537	PK-2537	FM-2537
HI-STEAM PND-5000	50 X 20 X 7	N/A	HS-1436	PK-1436	HB-1436
HI-STEAM PND-5000B		PKFM-2019	N/A	N/A	N/A
HI-STEAM EFB 500 XL	49 X 19 1/2 X 9	N/A	N/A	PK-1436	FB-1436
HI-STEAM 2500	44 X 15 X 9 1/2	N/A	N/A	PK-2163	FB-2163
HOFFMAN 1300	51 X 20 X 11	N/A	HS-2032	PK-2032	HB-2032
HOME IRONING BOARD	52 1/2 X 13 1/2 X 6	N/A	HS-741	N/A	HB-741
IOWA TECHNIQUES TUS	9 1/2 X 20	BKFB-2340	N/A	N/A	N/A
MAGIC VAPOR BOARD 1551	39 X 15 X 10	N/A	HS-1617	N/A	HB-1617
MCALLISTER MRS514	42 X 12 X 9	N/A	HS-1505	PK-1505	FM-1506
MCCLEARY	46 X 13 X 9	N/A	HS-504	N/A	HB-504
NORRIS/DRYCO #2501	39 X 15 X 10	N/A	HS-1617	N/A	HB-1617
OMEGA 2000		PKDB-2519	N/A	N/A	N/A
PACIFIC STEAM PSV-150	43 X 15 1/2 X 9	PKDB-2501	N/A	N/A	N/A
PACIFIC STEAM PSV-152SL	44 X 15 X 9	N/A	HS-1277	PK-1277	HB-1277
PACIFIC STEAM PSV-153	45 X 15 X 10	N/A	HS-504	N/A	HB-504
PACIFIC STEAM PN200	44 x 18 x 11	BKFB-2179	N/A	N/A	N/A
PACIFIC STEAM PSV300		N/A	HS-2422	N/A	HB-2422
PANTEX VB-1 STEAM VACUUM	47 X 15 X 9	N/A	HS-1132	N/A	HB-1132
PONY IDEA 5 SPOTTING BOARD	47 1/2 X 20	N/A	HS-1347	N/A	HB-1347
PONY IDEA 5 UTILITY BOARD	33 1/2 X 12 1/2 X 9 1/2	N/A	HS-1346	N/A	HB-1346
PONY VC/20P	48 X 16 X 11	N/A	HS-2037	N/A	HB-2037



FINISHING - IRONING BOARDS COVERS AND PADS

MODEL #	BOARD SIZE	COMBO PAD/COVER	HI-SPUN ARAMID COVER	PRO KNIT COVER	PAD
PONY SILVER	54 X 21 x 11	N/A	N/A	PK-2165	HB-2165
RIMAR IRONING BOARD	43 X 13 3/4 X 8 1/2	HFBN-1448	N/A	N/A	N/A
ROTONDI 2000	51 X 21 1/2 X 14	PKFM-2019	N/A	N/A	N/A
ROTONDI 2002	54 X 21 1/2 X 14	PKFM-2020	N/A	N/A	N/A
SAPORO SA70		PKDB-2501	N/A	N/A	N/A
SIDI MONDIAL VC904/AC	46 x 15 x 9	N/A	N/A	PK-2242	HB-2242
SUSSMAN PRS-40A	48 X 19 X 12 1/2	N/A	HS-1226	N/A	HB-1226
SUSSMAN MP80	50 x 21 x 16	N/A	HS-1927	N/A	HB-1927
SUSSMAN SV-244		N/A	N/A	PK-2452	FM-2452
SUSSMAN PB-323/PB323-A	50 1/2 X 24	N/A	HS-1561	N/A	HB-1561
SUSSMAN 424-HAB	45 X 15 X 10	N/A	HS-1289	PK-1289	HB-1289
SUSSMAN 424-HAB-C	56 X 15 X 9	NA	HS-1441	N/A	HB-1441
SUSSMAN SV-424	67 X 14	N/A	HS-1562	N/A	HB-1562
SUSSMAN 514-HAB	45 X 15 X 10	NA	HS-1289	PK-1289	HB-1289
SUSSMAN 524-HA	45 X 15 X 10	N/A	HS-504	N/A	HB-504
SUSSMAN 524HS	44 X 18 X 10	N/A	N/A	PK-2150	FB-2150
SUSSMAN STLK	43 X 13 1/2 X 6	N/A	HS-1415	N/A	HB-1415
TREVIL 2010	45 X 15 X 9	N/A	HS-1277	PK-1277	HB-1277
TREVIL 2120/2130	45 3/4 X 17 1/2 X 10	N/A	HS-1470	N/A	HB-1470
TREVIL 2434 VULKANA XL	55 x 19 x 10	N/A	N/A	PK-2161	FB-2161
TREVIL 3155	72 X 36	N/A	N/A	PK-2090	DB-2090
TREVIL 3454	50 x 20 x 9	N/A	N/A	PK-2025	DB-2025
UNIPRESS AFB	55 X 18 1/2 X 8	N/A	TA-1708	N/A	BF5-1792 5mm BF10-1786 10 mm (requires both)
UNIPRESS VB1		HSFB-5121			
VAPORPRESS LS30624	44 X 14 X 7	N/A	N/A	PK-2549	FM-2549
VEIT CR2	56 X 23 X 15	N/A	N/A	PK-1234	FM-1234
VEIT STANDARD, VELTRONIC 2000, VEIT 4216	45 X 15	N/A	N/A	PK-1250	HB-1250
VEIT 2210		N/A	N/A	PK-2642	FM-2642
VEIT 4419	51 X 26	N/A	HS-1294	N/A	HB-1294
VEIT 4440 S & B VAROSET	56 X 21 X 11	N/A	N/A	PK-2167	FM-2167
VEIT 14440300 10	49 X 20 X 12	N/A	HS-2097	N/A	FB-2097



**FORENTA/FORSE
EQUIPMENT**



22-BTA



60-AF-L

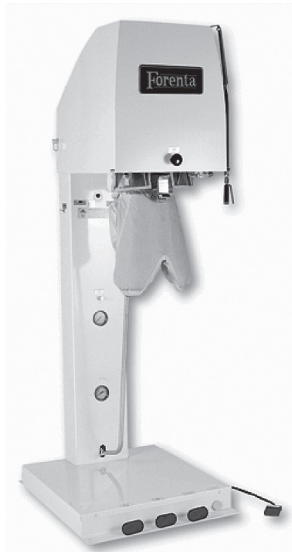

22-BP



8-TBS



471



FORENTA/FORSE BUCK PADS AND HEAD PLATES

MFG. MODEL NUMBER	BUCK SIZE	DESCRIPTION	BUCK PADS		HEAD PLATES		TEFLON GRID PLATE*
			PRO FINISH PAD/COVER		MASTER FINISH HEAD PLATE		
			TAN	RED	WHITE	BLACK	
18-VSPC	18 x 9	Mushroom	PRO-1078	RPRO-1078	N/A	N/A	TGP-123
19-ST 19-STH 19-SUH 19-VSPC 19-VST	20½ x 10½	Mushroom	PRO-690	RPRO-690	MFHP-116	BMFHP-116	TGP-116
21-VS	21 x 13 x 10	Topper	PRO-1187	RPRO-1187	MFHP-110	BMFHP-110	TGP-110
42-COS/COU	40 x 13 x 9	Utility-OFFSET	SEE PAGE 44				
42-FGR 42-FL 42-FOL 42-FOR 42-FR 42-SULB 42-SUR 42-SURB 42-SURM 42-VLR 42-YOLA 42-YOLB 42-YORB	40 x 13 x 9	Utility	PRO-832	RPRO-832	MFHP-18	BMFHP-18	TGP-18
46-FGR 46-FL 46-FOL 46-FOR 46-FR 46-SULB 46-SURB 46-UL 46-YOLB 46-YORB	44½ x 13 x 9	Utility	PRO-836	RPRO-836	MFHP-16	BMFHP-16	TGP-16

* Model Number Required

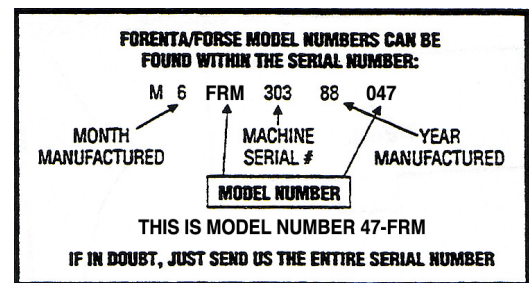
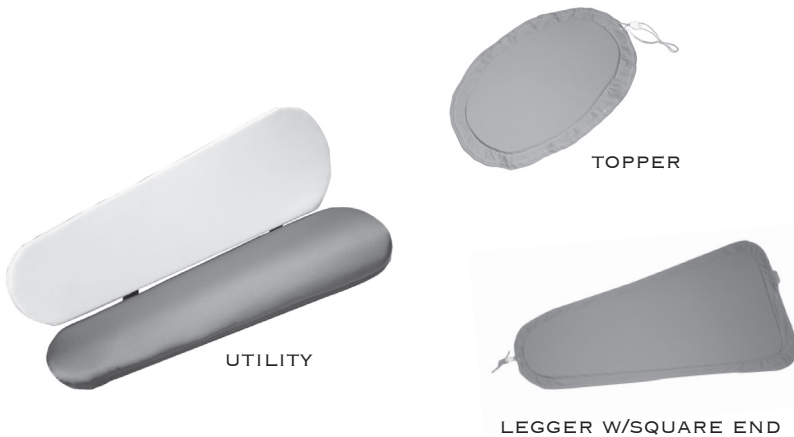

DRY CLEANING



FORENTA/FORSE BUCK PADS AND HEAD PLATES

MFG. MODEL NUMBER	BUCK SIZE	DESCRIPTION	BUCK PADS		HEAD PLATES		TEFLON GRID PLATE*
			PRO FINISH PAD/COVER		MASTER FINISH HEAD PLATE		
			TAN	RED	WHITE	BLACK	
47-FGL 47-FGR 47-FRM 47-LU 47-ML 47-MLR 47-MLS 47-SLM 47-SLR	43 x 17 ¹ / ₂ x 11	Legger w/Cut-Out	PRO-837	RPRO-837	MFHP-31	BMFHP-31	TGP-31
47-LSFG 47-LSFM 47-LSL	43 x 17 ¹ / ₂	Rectangular Legger w/Cut-Out	PRO-1525	RPRO-1525	MFHP-74	BMFHP-74	TGP-74
48-ASME 48-FGL 48-FGR 48-FRM 48-LC 48-RC 48-SLM 48-SLR	43 x 17 ¹ / ₂ x 8	Legger w/Cut-Out	PRO-828	RPRO-828	MFHP-36	BMFHP-36	TGP-36
48-VLMSE 48-VLNSE	43 x 18 x 8	Legger w/Tapered Square End	PRO-839	RPRO-839	MFHP-127	BMFHP-127	TGP-127
48-VLSA	43 x 17 ¹ / ₂	Rectangular Legger w/Cut-Out	PRO-1525	RPRO-1525	MFHP-74	BMFHP-74	TGP-74
181-VSPC	18 x 9	Mushroom	PRO-1078	RPRO-1078	MFHP-123	BMFHP-123	TGP-123
191-ST 191-STH 191-STMC 191-STMHC 191-SUH 191-VSPC 191-VST	20 ¹ / ₂ x 10 ¹ / ₂	Mushroom	PRO-690	RPRO-690	MFHP-116	BMFHP-116	TGP-116
211-VS	21 x 13 x 10	Topper	PRO-1187	RPRO-1187	MFHP-110	BMFHP-110	TGP-110
421-FGR 421-FL 421-FOL 421-FOR 421-FR 421-SULB 421-SUR 421-SURB 421-SURM 421-SURMC 421-VLR 421-YOLA 421-YOLB 421-YORB	40 x 13 x 9	Utility	PRO-832	RPRO-832	MFHP-18	BMFHP-18	TGP-18

* Model Number Required



**FORENTA/FORSE
BUCK PADS AND HEAD PLATES**

MFG. MODEL NUMBER	BUCK SIZE	DESCRIPTION	BUCK PADS		HEAD PLATES		TEFLON GRID PLATE*
			PRO FINISH PAD/COVER		MASTER FINISH HEAD PLATE		
			TAN	RED	WHITE	BLACK	
422-FGR 422-FL 422-FOL 422-FOR 422-FR 422-SULB 422-SUR 422-SURB 422-SURM 422-SURMC 422-VLR 422-YOLA 422-YOLB 422-YORB	40 x 13 x 9	Utility	PRO-832	RPRO-832	MFHP-18	BMFHP-18	TGP-18
423-MU (STOMPER)	42 x 12 x 9	Utility	PRO-842	RPRO-842	MFHP-20	BMFHP-20	TGP-20
461-FGR 461-FL 461-FOL 461-FOR 461-FR 461-SULB 461-SULMC 461-SUMOHC 461-SURB 461-SURMC 461-UL 461-YOLB 461-YORB	44 ¹ / ₂ x 13 x 9	Utility	PRO-836	RPRO-836	MFHP-16	BMFHP-16	TGP-16
462-FGR 462-FL 462-FOL 462-FOR 462-FR 462-SULB 462-SULMC 462-SULMC 462-SURB 462-SUMOHC 462-UL 462-YOLB 462-YORB	44 ¹ / ₂ x 13 x 9	Utility	PRO-836	RPRO-836	MFHP-16	BMFHP-16	TGP-16

* Model Number Required



**FORENTA/FORSE
BUCK PADS AND HEAD PLATES**

MFG. MODEL NUMBER	BUCK SIZE		BUCK PADS		HEAD PLATES		TEFLON GRID PLATE*	
			PRO FINISH PAD/COVER		MASTER FINISH HEAD PLATE			
			TAN	RED	WHITE	BLACK		
471-FGL 471-FGR 471-FRM 471-LU 471-ML 471-MLR 471-MLS 471-SLM 471-SLMAC 471-SLMC 471-SLR	43 x 17½ x 11		Legger w/Cut-Out	PRO-837	RPRO-837	MFHP-31	BMFHP-31	TGP-31
Center Leaf: OWN-2068								
471-LSFG 471-LSFM 471-LSL	43 x 17½		Rectangular Legger w/Cut-Out	PRO-1525	RPRO-1525	MFHP-74	BMFHP-74	TGP-74
472-FGL 472-FGR 472-FRM 472-LU 472-ML 472-MLR 472-MLS 472-SLM 472-SLMAC 472-SLMC 472-SLR	43 x 17½x 11		Legger w/Cut-Out	PRO-837	RPRO-837	MFHP-31	BMFHP-31	TGP-31
472-LS 472-LSFG 472-LSFM 472-LSL	43 x 17½		Rectangular Legger w/Cut-Out	PRO-1525	RPRO-1525	MFHP-74	BMFHP-74	TGP-74
481-ASME 481-FGL 481-FGR 481-FRM 481-LC 481-RC 481-SLM 481-SLR 481-SLMAC 481-SLMC	43 x 17½ x 8		Legger w/Cut-Out	PRO-828	RPRO-828	MFHP-36	BMFHP-36	TGP-36
Center Leaf: OWN-2068								
481-VLMSE 481-VLNSE	43 x 18 x 8		Legger w/Tapered Square End	PRO-839	RPRO-839	MFHP-127	BMFHP-127	TGP-127
481-VLSA	43 x 17½		Rectangular Legger w/Cut-Out	PRO-1525	RPRO-1525	MFHP-74	BMFHP-74	TGP-74

* Model Number Required



**FORENTA/FORSE
BUCK PADS AND HEAD PLATES**

MFG. MODEL NUMBER	BUCK SIZE	DESCRIPTION	BUCK PADS		HEAD PLATES		TEFLON GRID PLATE*
			PRO FINISH PAD/COVER		MASTER FINISH HEAD PLATE		
			TAN	RED	WHITE	BLACK	
482-ASME 482-FGL 482-FGR 482-FRM 482-LC 482-RC 482-SLM 482-SLR 482-SLMAC 482-SLMC	43 x 17½ x 8	Legger w/Cut-Out	PRO-828	RPRO-828	MFHP-36	BMFHP-36	TGP-36
482-VLMSE 482-VLNSE	43 x 18 x 8	Legger w/Tapered Square End	PRO-839	RPRO-839	MFHP-127	BMFHP-127	TGP-127
482-VLSA 482-LSFG	43 x 17½	Rectangular Legger w/Cut-Out	PRO-1525	RPRO-1525	MFHP-74	BMFHP-74	TGP-74
491-SLMAC	43 x 19½ x 15	Legger w/Cut-Out	PRO-2205	RPRO-2205	MFHP-2210	BMFHP-2210	TPG-2210
Center Leaf: OWN-2227							
591-SURMTC	60x17x11½	Utility	PRO-2518	RPRO-2518	MFHP-2630	BMFHP-2630	TPG-2630

* Model Number Required



**FORENTA/FORSE
HOT HEAD AND SILK PRESSES**

MFG.

MODEL
NUMBER

BUCK SIZE

DESCRIPTION

42-FOLH 42-FORH 42-FRH	40 x 13 x 9	Utility-SILK	SEE PAGE DC 42
46-FOLH 46-FORH 46-FRH 46-SULOH 461-SULMOHC	44 ¹ / ₂ x 13 x 9	Utility-SILK	SEE PAGE DC 42
191-SUMHC	20 ¹ / ₂ x 10 ¹ / ₂	Mushroom	SEE PAGE DC 42
472-FGRH	43 x 17 ¹ / ₂ x 11	Legger w/Cut-Out	SEE PAGE DC 42
482-FGRH	43 x 17 ¹ / ₂ x 8	Legger w/Cut-Out	SEE PAGE DC 42



FORENTA/FORSE COVERS AND PADS FOR PANTS TOPPERS

MFG. MODEL NUMBER	CLAMP SIZE	DESCRIPTION	INDEX NUMBER
22-BP	15 x 7 x 5	Cover & Pad Set for Pants Topper	1407
		Cover Only - 4553	960
		Foam Pad Only	961
		Topper Clamp Cover/Pad (2 Required)	CPDB-971
		TEXSTEEL Steel Base Pad (Diffuser)	TS-961
22-MTB FORK EXPANDER	15 x 7 x 5	Cover Only for Pants Topper - 26173	965
		Foam Pad Only	961
		Topper Clamp Cover/Pad (2 Required)	CPDB-971
		TEXSTEEL Steel Base Pad (Diffuser)	TS-961
		FLAN-O-WOOL Metal Flannel Pad	
22-MTB PLATE EXPANDER	15 x 7 x 5	Cover & Pad Set for Pants Topper	1407
		Cover Only - 4553	960
		Foam Pad Only	961
		Topper Clamp Cover/Pad (2 Required)	CPDB-971
		TEXSTEEL Steel Base Pad (Diffuser)	TS-961
22-PT	15 x 7 x 5	Cover & Pad Set for Pants Topper	1407
		Cover Only - 4553	960
		Foam Pad Only	961
		Topper Clamp Cover/Pad (2 Required)	CPDB-971
		TEXSTEEL Steel Base Pad (Diffuser)	TS-961
22-PTS	15 x 7 x 5	Cover & Pad Set for Pants Topper	1567
		Cover Only - 22619	1565
		Fly Cover	1570
		Foam Pad Only	961
		Topper Clamp Cover/Pad (2 Required)	CPDB-971
23-MP 23-MTA PLATE EXPANDER	15 x 7 x 5	Cover Only for Pants Topper - 4554	962
		Foam Pad Only	963
		Topper Clamp Cover/Pad (2 Required)	CPDB-971
		TEXSTEEL Steel Base Pad (Diffuser)	TS-963
		FLAN-O-WOOL Metal Flannel Pad	
23-MTA FORK EXPANDER	15 x 7 x 5	Cover Only for Pants Topper - 21785	967
		Foam Pad Only	963
		Topper Clamp Cover/Pad (2 Required)	CPDB-971
		TEXSTEEL Steel Base Pad (Diffuser)	TS-963
		FLAN-O-WOOL Metal Flannel Pad	
23-MTB 23-MTR	15 x 7 x 5	Cover Only for Pants Topper	969
		Foam Pad Only	970
		Topper Clamp Cover/Pad (2 Required)	CPDB-971
		TEXSTEEL Steel Base Pad (Diffuser)	TS-970
		FLAN-O-WOOL Metal Flannel Pad	



22-BP



22-PT

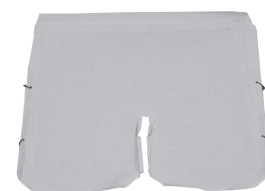

FLAN-O-WOOL

DRY CLEANING



FORENTA/FORSE

COVERS AND PADS FOR PANTS TOPPERS

MFG. MODEL NUMBER	CLAMP SIZE	DESCRIPTION	INDEX NUMBER
221-ET 222-BTAC 222-ETS	15 x 7 x 5	Cover & Pad Set for Pants Topper	1407
		Cover Only - 4553	960
		Foam Pad Only	961
		TEXSTEEL Steel Base Pad (Diffuser)	TS-961
		FLAN-O-WOOL Metal Flannel Pad	
		Topper Clamp Cover/Pad (2 Required)	CPDB-971
222-BTA 222-GTA	17 ³ / ₄ x 8 ¹ / ₄	Cover & Pad Set for Pants Topper	1407
		Cover Only - 4553	960
		Foam Pad Only	961
		Clamp Cover/Pad Set As Follows:	
		Foam Shoe Pad (2 Required)	982
		20 oz. Shoe Flannel (2 Required)	DB-979
		Shoe Cover (2 Required)	HT-978
		Shoe Outer Flannel (2 Required)	DB-981
		FLAN-O-WOOL Metal Flannel Pad	
		TEXSTEEL Steel Base Pad (Diffuser)	TS-961
224-BXT 225-BET 225-ET 225-ETS 9867 TOP-EZE		Cover & Pad Set for Pants Topper	1407
		Cover Only - 4553	960
		Foam Pad Only	961
		TEXSTEEL Steel Base Pad (Diffuser)	TS-961
		FLAN-O-WOOL Metal Flannel Pad	



222-BTA



**FORENTA/FORSE
COVERS AND PADS FOR STEAM AIR FINISHERS**

MFG. MODEL NUMBER	CLAMP SIZE	DESCRIPTION	INDEX NUMBER
55-FF		Mr. Finisher Steam Air Finisher Cover - 27775	964
57-FF	6 x 27	Front Clamp Cover/Pad	937
	4 x 24½	Rear Clamp Cover/Pad	977
59-MF		Mr. Finisher Steam Air Finisher Cover - 28047	964
	4 x 27	Front Clamp Cover/Pad	1207
	4 x 20½	Rear Clamp Cover/Pad	932
		TEXSTEEL Steel Yoke/Bib Pad	TS-964B
60-AF-L OMNI 60"		Steam Air Finisher Cover - LONG FORM- 29961	1095
		Netting Overbag	947
		Moisture Barrier	1236
	4 x 27	Front Clamp Cover/Pad	1207
60-AF-S OMNI 56"		Steam Air Finisher Cover - SHORT FORM- 29960	1094
		Netting Overbag	947
		Net Top Cover	908
		Moisture Barrier	1236
	4 x 27	Front Clamp Cover/Pad	1207
601-SA		Steam Air Finisher Cover - 28882	1097
	4 x 27	Front Clamp Cover/Pad	1207
	4 x 20½	Rear Clamp Cover/Pad	932
603-AFL 604-AFL 60"		Steam Air Finisher Cover - LONG FORM- 29961	1095
		Netting Overbag	947
		Moisture Barrier	1236
	4 x 27	Front Clamp Cover/Pad	1207
603-AFS 604-AFS 56"		Steam Air Finisher Cover - SHORT FORM- 29960	1094
		Netting Overbag	947
		Net Top Cover	908
		Moisture Barrier	1236
	4 x 27	Front Clamp Cover/Pad	1207
611-LAM		Steam Air Finisher Cover - 28882	1097
	4 x 27	Front Clamp Cover/Pad	1207
	4 x 20½	Rear Clamp Cover/Pad	932
TR-891		Shirt Suzie Cover	2255
		Netting Overbag	2258
		Skirt	2257
	4½ x 44½	Clamp Cover/Pad - Long	2262
	4½ x 40½	Clamp Cover/Pad - Short	2264
		Side Clamp Covers (2 Required)	2265



60-AF

**FORENTA/CINDY LOU
COVER AND PAD FOR SLEEVE FINISHER**

MFG. MODEL NUMBER	DESCRIPTION
80SF	See Page DC10
81SF	



**GOBUKSON
BUCK PADS AND HEAD PLATES**

		BUCK PADS		HEAD PLATES		
MFG. MODEL NUMBER	BUCK SIZE	PRO FINISH PAD/COVER		MASTER FINISH HEAD PLATE		TEFLON GRID PLATE*
		TAN	RED	WHITE	BLACK	
KMS-261 AD	45 x 18 x 9	PRO-885	RPRO-885	MFHP-2329	BMFHP-2329	TGP-2329

* Model Number Required

COVERS AND PADS FOR PANT TOPPERS

MFG. MODEL NUMBER	DESCRIPTION	INDEX NUMBER
MPT-1	Cover & Pad Set For Pants Topper	2683

**GOLDMAN
BUCK PADS AND HEAD PLATES**

			BUCK PADS		HEAD PLATES		
MFG. MODEL NUMBER	BUCK SIZE	DESCRIPTION	PRO FINISH PAD/COVER		MASTER FINISH HEAD PLATE		TEFLON GRID PLATE
			TAN	RED	WHITE	BLACK	
EZ-FAD-PLD	46 x 20 x 8	Legger w/Cut-Out	PRO-850	RPRO-850	Template Required*		
EZPL-1	42 x 18 x 10	Legger w/Cut-Out	PRO-843	RPRO-843	Template Required*		
EZPL-4	48 x 19 x 12 ¹ / ₂	Legger w/Cut-Out	PRO-848	RPRO-848	Template Required*		
EZKPH-6 EZPL-6 EZPLC-6 PAMPL-6	46 x 20 x 8	Legger w/Cut-Out	PRO-850	RPRO-850	Template Required*		
EZPT-10	21 x 10 x 8	Topper	PRO-822	RPRO-822	Template Required*		
EZ-19	19 x 9 ¹ / ₂	Mushroom	PRO-818	RPRO-818	Template Required*		
38 EZ-39-0	39 x 12 x 9	Utility	PRO-838	RPRO-838	Template Required*		
42 AOM-42 EKMK-42-0 EZ-42 EZ-42-0 EZK-42 EZK-42-0 GX-42-H EZX-42 PAM-42-0 EZ-43	42 x 12 x 9	Utility	PRO-842	RPRO-842	Template Required*		
EZ-45 EZK-45-0 EZM-45	45 x 13 x 9 ¹ / ₂	Utility	PRO-845	RPRO-845	Template Required*		
ML-47	44 ³ / ₄ x 18 x 9	Legger w/Cut-Out	PRO-885	RPRO-885	MFHP-1886		
48	46 x 14 x 9 ¹ / ₂	Utility	PRO-847	RPRO-847	Template Required*		
EZK-52-0	52 x 16 x 10	Utility	PRO-851	RPRO-851	Template Required*		

* For template instructions, see our Customer Service section.



HI-STEAM TENSIONING EQUIPMENT

MFG. MODEL NUMBER	DESCRIPTION	INDEX NUMBER
SAM-451 Shirt Finisher	Cover w/skirt	1995
	28" Clamp Cover/Pad	2012
	32" Clamp Cover/Pad	1997
	36" Clamp Cover/Pad	1999
	41" Clamp Cover/Pad	2008
	Cuff Clamp - Foam Cylinder Shaped Pads (Set of 4)	SET 2035
	Collar Support Cover	2038
	Side Clamp Cover - Fixed (2 Required)	WA-2118
	Side Clamp Cover w/Foam - Mobile (2 Required)	WAFM-2152
	Rear Clamp Cover w/Foam - Mobile	WAFM-2153
	Rear Clamp Cover - Fixed	WA-2171
	Silicone Pad for Cuff Clamp Stopper (Set of 2)	SET 2172
	1/4" Silicone Clamp Pad (4 Required) - wires to Cuff Clamp	BS-2215
JAM-510 Shirt Finisher	Shoulder Buck Cover	PK-2080
	Front Lapel Clamp Cover	2082
	Extension Bag - Lower Body	2084
	Front and Rear Clamp Cover (2 Required)	2086
JAZ-482 TURBO 483	Cover	2565
	30 Oz Flannel Pad	FB-2563
	Rear Clamp Cover/Pad	PKFB-1102
	Side Clamp Cover (Requires 2)	WA-1104
	Clamp Cover/Pad (Requires 2)	WAFB-1101
	Front Clamp Cover/Pad	WAJU-2622
	Long Sleeve Silicon Pad Cuff Clamp Stomper (Requires 2)	2624
	Short Sleeve Cuff Cover (Requires 4)	WK-2626
	Top Holder Clamp Cover (Requires 2)	WK-2628
	Rear Clamp Cover w/Sensor	WK-2564

**HOFFMAN
EQUIPMENT**

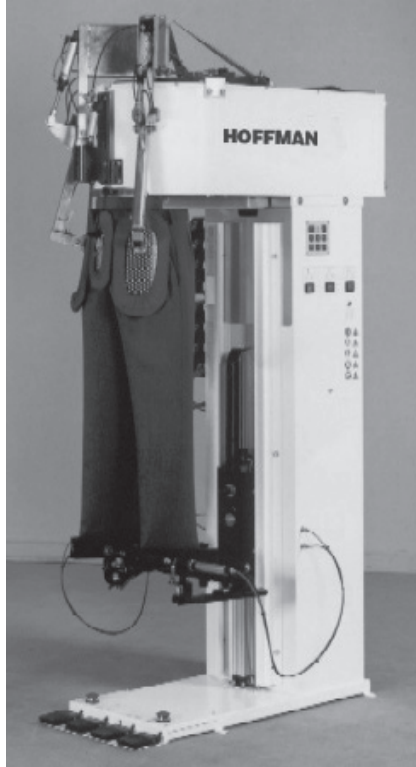

TOPMASTER II



JUDI II

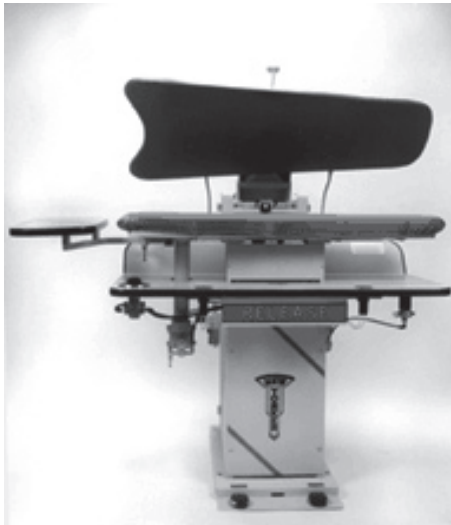

BC-46



M-1



FX-42



HOFFMAN/NEW YORKER/RHEEM BUCK PADS AND HEAD PLATES

MFG. MODEL NUMBER	BUCK SIZE	DESCRIPTION	BUCK PADS		HEAD PLATES		TEFLON GRID PLATE*
			PRO FINISH PAD/COVER		MASTER FINISH HEAD PLATE		
			TAN	RED	WHITE	BLACK	
M-1** W-1**	18 x 8½	Mushroom	PRO-818	RPRO-818	MFHP-3	BMFHP-3	TGP-3
CF-2 CO-2	51 x 14½ x 12½	Utility	PRO-851	RPRO-851	MFHP-56	BMFHP-56	TGP-56
W-2	18 x 8½	Mushroom	PRO-818	RPRO-818	MFHP-3	BMFHP-3	TGP-3
ASF-4	47 x 18 x 11	Legger w/Cut-Out	PRO-848	RPRO-848	MFHP-64	BMFHP-64	TGP-64
CF-4 CO-4	51 x 14½ x 12½	Utility	PRO-851	RPRO-851	MFHP-56	BMFHP-56	TGP-56
E-4 FXL-4	48 x 19½ x 12½	Legger w/Cut-Out	PRO-848	RPRO-848	MFHP-64	BMFHP-64	TGP-64
L-4	47 x 18½ x 11½	Legger w/Cut-Out	PRO-848	RPRO-848	MFHP-34	BMFHP-34	TGP-34
CF-5 CO-5	42 x 12 x 9	Utility	PRO-842	RPRO-842	MFHP-20	BMFHP-20	TGP-20
L-5	48 x 19½ x 12½	Legger w/Cut-Out	PRO-848	RPRO-848	MFHP-41	BMFHP-41	TGP-41
CF-6 CO-6	42 x 12 x 9	Utility	PRO-842	RPRO-842	MFHP-20	BMFHP-20	TGP-20
CO-7	37 x 11 x 8	Utility	PRO-838	RPRO-838	MFHP-11	BMFHP-11	TGP-11
BCL8S FB-L8S FX-L8S KPL-8S L-8 L-8S	44¾ x 18 x 9	Legger w/Cut-Out	PRO-885	RPRO-885	MFHP-68	BMFHP-68	TGP-68
CF-9 CO-9	46 x 12½ x 8½	Utility	PRO-847	RPRO-847	MFHP-22	BMFHP-22	TGP-22
B-10	21 x 10 x 8	Topper	PRO-820	RPRO-820	MFHP-5	BMFHP-5	TGP-5
CF-10 CO-10	46 x 12½ x 8½	Utility	PRO-847	RPRO-847	MFHP-22	BMFHP-22	TGP-22
E-10	42 x 18½ x 11½	Legger w/Cut-Out	PRO-843	RPRO-843	MFHP-29	BMFHP-29	TGP-29
T-10	21 x 10 x 8	Topper	PRO-820	RPRO-820	MFHP-8	BMFHP-8	TGP-8
T-11	21 x 10 x 8	Topper	PRO-820	RPRO-820	MFHP-4	BMFHP-4	TGP-4
T-11-A	21 x 10 x 8	Topper	PRO-820	RPRO-820	MFHP-6	BMFHP-6	TGP-6
GH-12	45 x 19½ x 10	Legger w/Cut-Out	PRO-885	RPRO-885	MFHP-68	BMFHP-68	TGP-68
W-12	18 x 8½	Mushroom	PRO-818	RPRO-818	MFHP-3	BMFHP-3	TGP-3

** **HSFB-1948** (Heat Resistant Metal Base Insulation Cover/Pad) is available. * Model Number Required



**HOFFMAN/NEW YORKER/RHEEM
BUCK PADS AND HEAD PLATES**

MFG. MODEL NUMBER	BUCK SIZE	DESCRIPTION	BUCK PADS		HEAD PLATES		TEFLON GRID PLATE*
			PRO FINISH PAD/COVER		MASTER FINISH HEAD PLATE		
			TAN	RED	WHITE	BLACK	
B-15	23 x 10 ¹ / ₂ x 8	Topper	PRO-822	RPRO-822	MFHP-106	BMFHP-106	TGP-106
B-16	21 x 10 x 8	Topper	PRO-820	RPRO-820	MFHP-5	BMFHP-5	TGP-5
B-17	21 x 10 x 8	Topper	PRO-820	RPRO-820	MFHP-69	BMFHP-69	TGP-69
CO-17	47 x 12 x 9	Utility	PRO-887	RPRO-887	MFHP-46	BMFHP-46	TGP-46
T-17	20 x 9 x 8	Topper	PRO-817	RPRO-817	MFHP-69	BMFHP-69	TGP-69
CO-18	47 x 12 x 9	Utility	PRO-887	RPRO-887	MFHP-46	BMFHP-46	TGP-46
19-CM 19-CMX 19-SM 19-SMX UA M1-19	18 x 8 ¹ / ₂ 18 x 8 ¹ / ₄	Mushroom	PRO-818	RPRO-818	MFHP-3	BMFHP-3	TGP-3
HSE-20-P	42 x 18 ¹ / ₄ x 9 ¹ / ₂	Legger w/Cut-Out	PRO-843	RPRO-843	MFHP-29	BMFHP-29	TGP-29
21-CT 21-CTX 21-ST 21-STX	21 x 10 x 8	Topper	PRO-820	RPRO-820	MFHP-5	BMFHP-5	TGP-5
CF-24 CO-24	51 x 14 ¹ / ₂ x 8 ¹ / ₂	Utility	PRO-851	RPRO-851	MFHP-56	BMFHP-56	TGP-56
38 38-CG 38-SG 38-SGX	38 x 12 x 9	Utility	PRO-838	RPRO-838	MFHP-11	BMFHP-11	TGP-11
SEALD-40	47 x 18 x 11	Legger w/Cut-Out	PRO-848	RPRO-848	MFHP-34	BMFHP-34	TGP-34
42 42-CG 42-SG 42-SGX	42 x 12 x 9	Utility	PRO-842	RPRO-842	MFHP-20	BMFHP-20	TGP-20
42-CL 42-CLX 42-SL 42-SLX	42 x 18 ¹ / ₂ x 11 ¹ / ₂	Legger w/Cut-Out	PRO-843	RPRO-843	MFHP-29	BMFHP-29	TGP-29

* Model Number Required



**HOFFMAN/NEW YORKER/RHEEM
BUCK PADS AND HEAD PLATES**

MFG. MODEL NUMBER	BUCK SIZE	DESCRIPTION	BUCK PADS		HEAD PLATES		TEFLON GRID PLATE*
			PRO FINISH PAD/COVER		MASTER FINISH HEAD PLATE		
			TAN	RED	WHITE	BLACK	
AA-42 BC-42 BC-42SC EC-42 ES-42 FB-42 FX-42 FX-42SC HDS-42 PS-42 UA-42 UA-42OL	42 x 12 x 9	Utility	PRO-842	RPRO-842	MFHP-20	BMFHP-20	TGP-20
45-0 AA-45 FB-45 FX-45 OS-45 SW-45-O SW-45-R UA-45 UA-45OL	45 x 12 x 9	Utility	PRO-845	RPRO-845	MFHP-24	BMFHP-24	TGP-24
46-CG 46-CGX 46-SG 46-SGX	46 x 14 ¹ / ₂ x 8 ¹ / ₂	Utility	PRO-847	RPRO-847	MFHP-22	BMFHP-22	TGP-22
46-SLAN 46-T BC-46 BC-46SC FB-46 FX-46SC UCAL-46T	45 x 19 ¹ / ₂ x 10 44 ³ / ₄ x 18 x 9	Legger w/Cut-Out	PRO-885	RPRO-885	MFHP-68	BMFHP-68	TGP-68
46-SL 46-SLA	46 x 21 x 11	Legger w/Cut-Out	PRO-897	RPRO-897	MFHP-77	BMFHP-77	TGP-77
HSE-48-P	48 x 19 ¹ / ₂ x 12 ¹ / ₂	Legger w/Cut-Out	PRO-848	RPRO-848	MFHP-64	BMFHP-64	TGP-64
48	45 x 20 ¹ / ₄ x 9	Legger w/Cut-Out	PRO-849	RPRO-849	MFHP-77	BMFHP-77	TGP-77
48-0	46 x 14 ¹ / ₂ x 8 ¹ / ₂	Utility	PRO-847	RPRO-847	MFHP-49	BMFHP-49	TGP-49
52	52 x 15 ¹ / ₄ x 9 ¹ / ₄	Utility	PRO-851	RPRO-851	MFHP-47	BMFHP-47	TGP-47
52-CG 52-CGX 52-SG 52-SGX	52 x 15 ¹ / ₄ x 9 ¹ / ₄	Utility	PRO-851	RPRO-851	MFHP-56	BMFHP-56	TGP-56

* Model Number Required

DRY CLEANING



HOFFMAN/NEW YORKER/RHEEM BUCK PADS AND HEAD PLATES

MFG. MODEL NUMBER	BUCK SIZE	DESCRIPTION	BUCK PADS		HEAD PLATES		TEFLON GRID PLATE*
			PRO FINISH PAD/COVER		MASTER FINISH HEAD PLATE		
			TAN	RED	WHITE	BLACK	
CF-56 CO-56	42 x 12 x 9	Utility	PRO-842	RPRO-842	MFHP-20	BMFHP-20	TGP-20
W-78	15 ¹ / ₂ x 7 ¹ / ₂	Mushroom	PRO-815	RPRO-815	MFHP-63	BMFHP-63	TGP-63
HSEL-80-P SEAL-80-S	45 x 19 ¹ / ₂ x 10	Legger w/Cut-Out	PRO-885	RPRO-885	MFHP-68	BMFHP-68	TGP-68
CO-90	46 x 14 ¹ / ₂ x 8 ¹ / ₂	Utility	PRO-847	RPRO-847	MFHP-22	BMFHP-22	TGP-22
B-100	21 x 10 x 8	Topper	PRO-820	RPRO-820	MFHP-5	BMFHP-5	TGP-5
E-100 HSE-100 SEAL-100	42 x 18 ¹ / ₂ x 11 ¹ / ₂	Legger w/Cut-Out	PRO-843	RPRO-843	MFHP-29	BMFHP-29	TGP-29
CO-170	47 x 12 x 9	Utility	PRO-887	RPRO-887	MFHP-46	BMFHP-46	TGP-46

* Model Number Required

HOFFMAN/NEW YORKER/RHEEM DOUBLE LAPEL DRYCLEANING PRESS

MFG. MODEL NUMBER	DESCRIPTION	INDEX NUMBER
UACB 20	Set includes: (1) Left PRO-KNIT Cover (1) Right PRO-KNIT Cover (2) 30 oz. BONN-E-BLUE Flannel Pads	SET-1248
UACB 21	Set includes: (1) Left PRO-KNIT Cover (1) Right PRO-KNIT Cover (2) 30 oz. BONN-E-BLUE Flannel Pads (2) 1/4" Silicone Foam Pad	SET-1212

HOFFMAN/NEW YORKER COVERS AND PADS FOR KORRECT KOLLAR

MFG. MODEL NUMBER	DESCRIPTION	INDEX NUMBER
K-30	Cover for Korrect Kollar Pad for Korrect Kollar	BK-682 H-682
K-37	Cover for Korrect Kollar Pad for Korrect Kollar	BK-683 H-683



**HOFFMAN/NEW YORKER/RHEEM
HOT HEADS AND SILK PRESSES**

MFG. MODEL NUMBER	BUCK SIZE	DESCRIPTION	
19-HM	18 x 8 ¹ / ₂	Mushroom - Hot Head	SEE PAGE DC 43
19-HMX	18 x 8 ¹ / ₂	Mushroom - Hot Head	
21-HT	21 x 10 x 8	Topper - Hot Head	SEE PAGE DC 43
21-HTX	21 x 10 x 8	Topper - Hot Head	
38-HGX	38 x 12 x 9	Utility - Silk	SEE PAGE DC 43
UA-42HHOL	42 x 12 x 9	Utility	SEE PAGE DC 43
SW-42 SILK	42 x 12 x 9	Utility - Silk	
42-HGX	42 x 12 x 9	Utility - Silk	
45-HOX	45 x 12 x 9	Utility	SEE PAGE DC 43
BC-45 HHR	45 x 12 x 9	Utility - Silk	
SW-45 ROS	45 x 12 x 9	Utility - Silk	
UA-45HHOL	45 x 12 x 9	Utility	
46-HG	46 x 14 ¹ / ₂ x 8 ¹ / ₂	Utility - Silk	SEE PAGE DC 43
46-HGX	46 x 14 ¹ / ₂ x 8 ¹ / ₂	Utility - Silk	
47-HG	47 x 15 ¹ / ₄ x 9 ¹ / ₄	Utility - Silk	SEE PAGE DC 43
52-HG	52 x 15 ¹ / ₄ x 9 ¹ / ₄	Utility - Silk	SEE PAGE DC 43
52-HGX	52 x 15 ¹ / ₄ x 9 ¹ / ₄	Utility - Silk	SEE PAGE DC 43

HOFFMAN

COVERS AND PADS FOR COLLAR FORM AND STEAM AIR FINISHERS

MFG. MODEL NUMBER	CLAMP SIZE	DESCRIPTION	INDEX NUMBER
DC-9		Cover for Collar Form Pad for Collar Form	BK-909 H-909
3536 through 3538		Cover for Collar Form Pad for Collar Form	BK-691 H-691
3545		Coat-A-Matic Steam Air Finisher Cover Nomex Boot Buck Felt Pad DF Cotton Front Breast Pad (Under Cover) DF Cotton Rear Pad (Under Cover) Jupiter Head Pad/Cover w/Sidewall Front Clamp Cover/Pad Rear Clamp Cover/Pad	988 OWN-987 987 DFC-1466 DFC-1417 JUH-986 990 924
FORMASTER	4 ¹ / ₂ x 9 x 34 4 x 24 ¹ / ₂	Steam Air Finisher Cover	2520

DRY CLEANING



HOFFMAN TENSIONING PANTS TOPPERS

MFG. MODEL NUMBER	CLAMP SIZE	DESCRIPTION	INDEX NUMBER
T-811		Fly Clamp Cover/Pad Set includes: Pant Topper Cover/Pad made with PRO-KNIT Cover Cloth & 24 oz. JUPITER Pad (2) PRO-KNIT Clamp Covers (Left and Right) — each with a 30 oz. and 50 oz. Pad	PKFB-1114 SET-1100
TOPMASTER II	6 ³ / ₄ x 11 ¹ / ₂ 2 ³ / ₄ x 8 ³ / ₄	Pant Topper Cover and Pad Set Clamp Cover/Pad (Requires 2) Fly Clamp Cover/Pad Rear Cover	2062 PKDB-2070 PKDB-2072 PK-2073

HOFFMAN TENSIONING SHIRT FINISHER

MFG. MODEL NUMBER	DESCRIPTION	INDEX NUMBER
RS-4000	Cover w/ attached skirt	2598

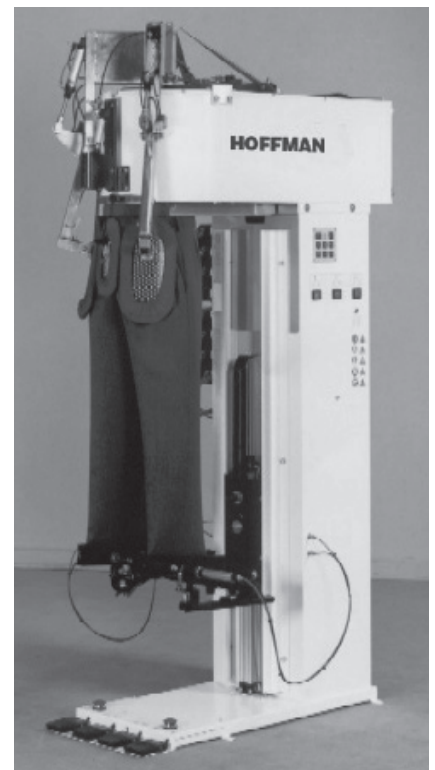

TOPMASTER II



**HOT HEADS AND SILK PRESSES
COVERS AND PADS**

MFG. MODEL NUMBER	BUCK SIZE	DESCRIPTION	HI-SPUN ARAMID COVER	50 OZ. BONN-E-BLUE PAD	TAN PRO PAD/COVER	TEXSTEEL STEEL BASE PAD - BARE BUCK ONLY
AJAX DCH-18 DCHB-18	18 ¹ / ₂ x 9 ¹ / ₄	Mushroom	HS-818	HB-818	PRO-818	TS-818
DCH-45 DCHB-45 HOU-45-C (#405) HOU-45/L (#405) HOUB-45/L (#605)	44 ¹ / ₂ x 11 ¹ / ₂ x 8	Utility	HS-845	HB-845	PRO-845	TS-845
DCH-446 DCHF-446 DCHB-446 DCHFB-446	46 x 20 x 8 ¹ / ₄	Legger	HS-850	HB-850	PRO-850	TS-850
CISSELL AUH-42 AURH-42 MUH-42	41 x 13 x 9	Utility	HS-840	HB-840	PRO-840	TS-840
AUH-45 AURH-45 MUH-45	45 x 12 x 9	Utility	HS-845	HB-845	PRO-845	TS-845
FORENTA 19-STH 19-STMHC 19-SUH 19-SUMHC 191-STMHC 191-SUMHC	20 ¹ / ₂ x 10 ¹ / ₂	Mushroom	HS-690	HB-690	PRO-690	TS-690
42-FOLH 42-FORH 42-FRH	40 x 13 x 9	Utility	HS-832	HB-832	PRO-832	TS-832
46-FOLH 46-FORH 46-FRH 46-SULOH 461-SULMOHC	44 ¹ / ₂ x 13 x 9	Utility	HS-836	HB-836	PRO-836	TS-836
472-FGRH	43 x 17 ¹ / ₂ x 11	Legger w/ Cut-out	HS-837	HB-837	PRO-837	TS-837
482-FGRH	43 x 17 ¹ / ₂ x 8	Legger w/ Cut-out	HS-828	HB-828	PRO-828	TS-828

DRY CLEANING



HOT HEADS AND SILK PRESSES COVERS AND PADS

MFG. MODEL NUMBER	BUCK SIZE	DESCRIPTION	HI-SPUN ARAMID COVER	50 OZ. BONN-E-BLUE PAD	TAN PRO PAD/COVER	TEXSTEEL STEEL BASE PAD - BARE BUCK ONLY
HOFFMAN/NEWYORKER/RHEEM						
19-HM 19-HMX	18 x 8 ¹ / ₂	Mushroom	HS-818	HB-818	PRO-818	TS-818
21-HT 21-HTX	21 x 10 x 8	Topper	HS-820	HB-820	PRO-820	TS-820
38-HGX	38 x 12 x 9	Utility	HS-838	HB-838	PRO-838	TS-838
42-HGX SW-42SILK UA-42HHOL	42 x 12 x 9	Utility	HS-842	HB-842	PRO-842	TS-842
45-HOX BC-45HHR SW-45-ROS SILK UA-45HHOL	45 x 12 x 9	Utility	HS-845	HB-845	PRO-845	TS-845
46-HG 46-HGX	46 x 14 ¹ / ₂ x 8 ¹ / ₂	Utility	HS-847	HB-847	PRO-847	TS-847
47-HG	47 x 15 ¹ / ₄ x 9 ¹ / ₄	Utility	HS-887	HB-887	PRO-887	TS-887
52-HG 52-HGX	52 x 15 ¹ / ₄ x 9 ¹ / ₄	Utility	HS-851	HB-851	PRO-851	TS-851
MIRACLEAN						
MCU-H	47 x 14 x 9	Utility	HS-1258	HB-1258	PRO-1258	N/A
STIRMATIC						
PAGSL	45 ¹ / ₄ x 17 x 10	Utility/Legger	HS-1276	HB-1276	PRO-1276	N/A
PAUL	46 x 13 ¹ / ₄ x 10	Utility	HS-883	HB-883	PRO-883	N/A
UNIPRESS						
GBH-42 SDH-42 42XH 42YH	42 x 12 x 9	Utility	HS-842	HB-842	PRO-842	TS-842
45HOX	45 x 12 x 9	Utility	HS-845	HB-845	PRO-845	TS-845
46HX	46 x 19 x 8 ¹ / ₂	Legger w/cut-out	HS-850	HB-850	PRO-850	TS-850

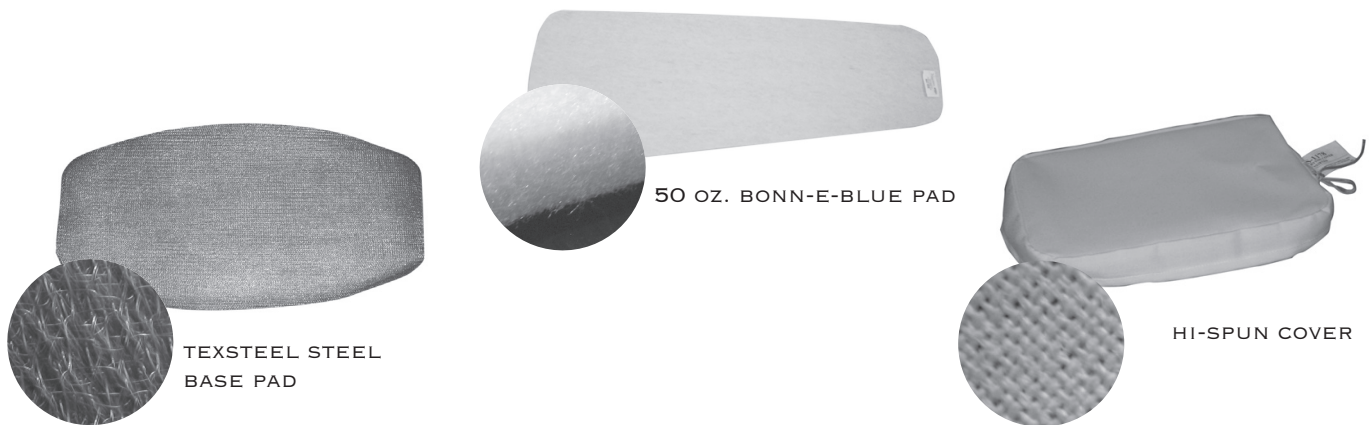



HUEBSCH (GLOVER)

COVERS AND PADS FOR STEAM AIR FINISHERS

MFG. MODEL NUMBER	CLAMP SIZE	DESCRIPTION	INDEX NUMBER
SAF-1		Steam Air Finisher Set	974
SAF-2		Set Contains:	
SAF-3		Steam Air Finisher Cover	973
		Vest	976
		Moisture Sleeve	975
	4 x 33	Front Clamp Cover/Pad	916
	4 x 24	Rear Clamp Cover/Pad	924

HWA SUNG

COVERS AND PADS FOR PANTS TOPPERS

MFG. MODEL NUMBER	SIZE	DESCRIPTION	INDEX NUMBER
HS-2008	17 x 17	Cover and Pad Set for Pants Topper - Large	2108
	15 x 17	Cover and Pad Set for Pants Topper - Small	2106
	7 x 14	Clamp Cover/Pad (2 required)	PKFM-2109

IOWA TECHNIQUES/CINDY LOU

COVERS AND PADS FOR SLEEVE MASTER

MFG. MODEL NUMBER	DESCRIPTION
SLEEVE MASTER	See Page DC 10

ITSUMI

COVERS AND PADS FOR PANT TOPPERS

MFG. MODEL NUMBER	DESCRIPTION	INDEX NUMBER
T0322A	Cover & Pad Set for Pants Topper	2682

KONEIG

SHIRT TENSIONER

MFG. MODEL NUMBER	DESCRIPTION	INDEX NUMBER
482	Cover Front & Rear (Set/2)	2443 Set DB-2446

KUM SUNG

BUCK PADS AND HEAD PLATES

MFG. MODEL NUMBER	BUCK SIZE	DESCRIPTION	BUCK PADS		HEAD PLATES		TEFLON GRID PLATE*
			PRO FINISH PAD/COVER		MASTER FINISH HEAD PLATE		
			TAN	RED	WHITE	BLACK	
KSP-M2A	23 x 13	Mushroom	PRO-2180	RPRO-2180	MFHP-2174	BMFHP-2174	TGP-2174

* Model Number Required

DRY CLEANING



MCCALLISTER BUCK PADS AND HEAD PLATES

MFG. MODEL NUMBER	BUCK SIZE	DESCRIPTION	BUCK PADS		HEAD PLATES		TEFLON GRID PLATE*
			PRO FINISH PAD/COVER		MASTER FINISH HEAD PLATE		
			TAN	RED	WHITE	BLACK	
MRS-108-A	45 x 18 x 9	Legger w/Cut-Out	PRO-885	RPRO-885	MFHP-246	BMFHP-246	TGP-246
MRS-111-A	21 x 10 x 8	Topper	PRO-820	RPRO-820	MFHP-6	BMFHP-6	TGP-6
MRS-042 MRS-142-A	42 x 12 x 9	Utility	PRO-842	RPRO-842	MFHP-20	BMFHP-20	TGP-20

* Model Number Required

MCCALLISTER COVERS AND PADS FOR PANTS TOPPERS

MFG. MODEL NUMBER	DESCRIPTION	INDEX NUMBER
DC	Pant Topper Cover & Pad Set	2010

MIRACLEAN BUCK PADS AND HEAD PLATES

MFG. MODEL NUMBER	BUCK SIZE	DESCRIPTION	BUCK PADS		HEAD PLATES		TEFLON GRID PLATE*
			PRO FINISH PAD/COVER		MASTER FINISH HEAD PLATE		
			TAN	RED	WHITE	BLACK	
MCL MCLSC	47 x 18 x 13	Legger w/Cut-Out	PRO-1275	RPRO-1275	MFHP-156	BMFHP-156	TGP-156
MCLU	47 x 18 x 9	Utility/Legger w/Cut-Out/Round End	PRO-1416	RPRO-1416	MFHP-159	BMFHP-159	TGP-159
MCU MCU-O MCUSC	47 x 14 x 9	Utility	PRO-1258	RPRO-1258	MFHP-150	BMFHP-150	TGP-150
S/EP1	47 x 18 x 13	Legger w/Cut-Out	PRO-1275	RPRO-1275	MFHP-156	BMFHP-156	TGP-156
S/EP4	47 x 14 x 9	Utility	PRO-1258	RPRO-1258	MFHP-150	BMFHP-150	TGP-150
S/EP5	48 x 18 x 9	Utility/Legger w/Cut-Out/Round End	PRO-1416	RPRO-1416	MFHP-159	BMFHP-159	TGP-159

* Model Number Required

MIRACLEAN COVERS AND PADS FOR STEAM AIR FINISHERS AND PANTS TOPPERS

MFG. MODEL NUMBER	CLAMP SIZE	DESCRIPTION	INDEX NUMBER
S/TP		Cover and Pad Set for Pants Topper	1409
S/VC	4 x 39	Steam Air Finisher Cover Front Clamp Cover/Pad	1282 1205



OFFSET PRESSES COVERS AND PADS

		COVER	PAD	COMBO
MFG. MODEL NUMBER	BUCK SIZE	HI-SPUN ARAMID	50 OZ. BONN-E- BLUE	TAN PRO PAD/ COVER
AJAX SO 42	41½ x 12 x 7	HS-651	HB-651	N/A
CISELL LOPZ CISELL OPB CISELL OPC CISELL OPL	41 x 12 x 9	HS-841	HB-841	PRO-841
EXCELSIOR 300	42 x 12 x 8	HS-841	HB-841	PRO-841
FORENTA 42-COS/COU	40 x 13 x 9	HS-832	HB-832	PRO-832
GLOVER VF	42 x 14 x 7	HS-1308	HB-1308	N/A
HOFFMAN SVCO 25	42 x 12 x 9	HS-841	HB-841	PRO-841
UNIPRESS DOC-47	47 x 16 x 9	HS-884	HB-884	PRO-884

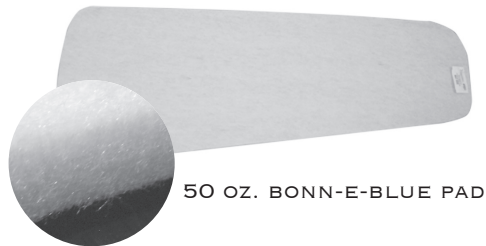
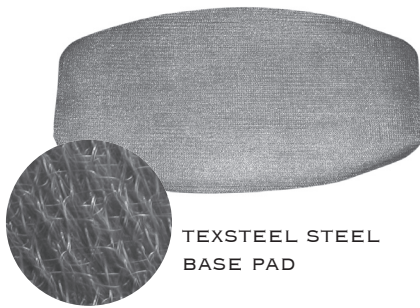



**PANTEX
BUCK PADS AND HEAD PLATES**

MFG. MODEL NUMBER	BUCK SIZE	DESCRIPTION	BUCK PADS		HEAD PLATES		TEFLON GRID PLATE*
			PRO FINISH PAD/COVER		MASTER FINISH HEAD PLATE		
			TAN	RED	WHITE	BLACK	
15-DO	15 x 9	Mushroom	PRO-815	RPRO-815	MFHP-99	BMFHP-99	TGP-99
M-19	18 x 9 ¹ / ₂	Mushroom	PRO-818	RPRO-818	MFHP-2	BMFHP-2	TGP-2
M-20	18 x 10						
M-21-DO	22 x 10 x 7	Topper	PRO-822	RPRO-822	MFHP-9	BMFHP-9	TGP-9
M-24							
40	39 ¹ / ₂ x 12 x 8	Utility	PRO-840	RPRO-840	MFHP-21	BMFHP-21	TGP-21
41	40 x 12 x 8	Utility	PRO-840	RPRO-840	MFHP-21	BMFHP-21	TGP-21
M-41							
PA-41							
U-41	40 ³ / ₄ x 12 ¹ / ₂ x 8 ³ / ₄						
43	42 x 18 ¹ / ₂ x 11	Legger w/Cut-Out	PRO-834	RPRO-834	MFHP-37	BMFHP-37	TGP-37
SM-44	43 x 19 x 11	Legger w/Cut-Out	PRO-894	RPRO-894	MFHP-76	BMFHP-76	TGP-76
45	43 ¹ / ₂ x 12 x 8	Utility	PRO-845	RPRO-845	MFHP-54	BMFHP-54	TGP-54
PA-45	43 ¹ / ₂ x 12 x 8						
U-45	44 x 12 ¹ / ₂ x 9						
U-46	46 x 18 x 9 ¹ / ₄	Legger	PRO-844	RPRO-844	MFHP-53	BMFHP-53	TGP-53
PA-47	46 x 14 ¹ / ₂ x 9	Utility	PRO-847	RPRO-847	MFHP-22	BMFHP-22	TGP-22
U-47							
U-47-B	45 x 18 x 8 ¹ / ₂	Legger w/Cut-Out	PRO-895	RPRO-895	MFHP-72	BMFHP-72	TGP-72
52	51 x 16 ¹ / ₂ x 11	Utility	PRO-851	RPRO-851	MFHP-56	BMFHP-56	TGP-56
M-441	43 x 19 ¹ / ₂ x 12	Legger w/Cut-Out	PRO-834	RPRO-834	MFHP-37	BMFHP-37	TGP-37
PA-444	43 x 17 ¹ / ₂ x 11	Legger w/Cut-Out	PRO-805	RPRO-805	MFHP-121	BMFHP-121	TGP-121
U-475	45 x 18 x 8 ¹ / ₂	Legger w/Cut-Out	PRO-895	RPRO-895	MFHP-72	BMFHP-72	TGP-72
M-480-O	47 x 18 ¹ / ₂ x 11 ¹ / ₂	Legger w/Cut-Out	PRO-848	RPRO-848	MFHP-39	BMFHP-39	TGP-39
M-481-F							

* Model Number Required



PARIS COVERS AND PADS FOR STEAM AIR FINISHERS

MFG. MODEL NUMBER	CLAMP SIZE	DESCRIPTION	INDEX NUMBER
MASTER		Steam Air Finisher Cover	995
	3 x 35	Front Clamp Cover/Pad	1092
	3 x 31	Rear Clamp Cover/Pad	1093

PONY/SIDI/CAMPTEL BUCK PADS AND HEAD PLATES

MFG. MODEL NUMBER	BUCK SIZE	DESCRIPTION	BUCK PADS		HEAD PLATES		TEFLON GRID PLATE*
			PRO FINISH PAD/COVER		MASTER FINISH HEAD PLATE		
			TAN	RED	WHITE	BLACK	
LEgger	47 x 19 x 13	Legger w/Cut-Out	PRO-1275	RPRO-1275	MFHP-156	BMFHP-156	TGP-156
UTILITY	48 x 16 ¹ / ₄ x 10	Utility	PRO-1225	RPRO-1225	MFHP-148	BMFHP-148	TGP-148

* Model Number Required

PONY/SIDI/CAMPTEL/GIDINE STEAM AIR FINISHERS, PANTS TOPPERS AND TENSIONING EQUIPMENT

MFG. MODEL NUMBER	CLAMP SIZE	DESCRIPTION	INDEX NUMBER
COSMOS		Steam Air Finisher Cover	2159
IDEA-5		Steam Air Finisher Cover	1218
	4 x 36	Front Clamp Cover/Pad	956
	4 x 24	Rear Clamp Cover/Pad	924
405	4x32	Shirt Finisher Cover	2605
		Front Blade Cover	2607
		Side Clamp Covers (2 Required)	2608
IDEA-5		Cover only for Pants Topper	1227
MG-399		Steam Air Finisher Cover	1483
MPT-A	7 x 13	Cover and Pad Set for Pants Topper	1405
		Pleat Pad/Cover (2 Required)	CPDB-1651
MPT-B		Cover Only for Pants Topper	1227
MPT-DP2		Cover and Pad Set for Pant Topper	2420
		Silicone Foam Pad	2496
		Rear Cover	PK-2073
MPT-37		Cover and Pad Set for Pants Topper	1575
		Fly Cover	PK-1582
MPT-37P2	6 ³ / ₄ x 11 ¹ / ₂ 2 ³ / ₄ x 8 ³ / ₄	Cover and Pad Set for Pants Topper	2062
		Pleat Pad/Cover (2 Required)	PKDB-2070
		Fly Clamp Cover Pad	PKDB-2072
		Rear Cover	PK-2073
MPT-38P		Cover and Pad Set for Pants Topper	2050
		Fly Cover	2052



**PROSPERITY
BUCK PADS AND HEAD PLATES**

MFG. MODEL NUMBER	BUCK SIZE	DESCRIPTION	BUCK PADS		HEAD PLATES		TEFLON GRID PLATE*
			PRO FINISH PAD/COVER		MASTER FINISH HEAD PLATE		
			TAN	RED	WHITE	BLACK	
LD-50	48 x 14 x 7	Utility	PRO-870	RPRO-870	MFHP-48	BMFHP-48	TGP-48
118 218	17½ x 8	Mushroom	PRO-818	RPRO-818	MFHP-2	BMFHP-2	TGP-2
237 237-EZD	37½ x 11 x 8	Utility	PRO-838	RPRO-838	MFHP-15	BMFHP-15	TGP-15
249	47 x 19½ x 11½	Legger w/Cut-Out	PRO-898	RPRO-898	MFHP-39	BMFHP-39	TGP-39
250	48 x 14 x 7	Utility	PRO-870	RPRO-870	MFHP-48	BMFHP-48	TGP-48
318	18½ x 9	Mushroom	PRO-818	RPRO-818	MFHP-3	BMFHP-3	TGP-3
343	43 x 13 x 8½	Utility	PRO-842	RPRO-842	MFHP-20	BMFHP-20	TGP-20
442	42 x 18½ x 11	Legger w/Cut-Out	PRO-834	RPRO-834	MFHP-52	BMFHP-52	TGP-52
443	42 x 12 x 9	Utility	PRO-842	RPRO-842	MFHP-20	BMFHP-20	TGP-20
542	42 x 18½ x 11	Legger w/Cut-Out	PRO-834	RPRO-834	MFHP-52	BMFHP-52	TGP-52
719	20¼ x 9½ x 8½	Topper	PRO-820	RPRO-820	MFHP-8	BMFHP-8	TGP-8
720	20½ x 9 x 7½	Topper	PRO-820	RPRO-820	MFHP-7	BMFHP-7	TGP-7
743	42 x 12 x 9	Utility	PRO-842	RPRO-842	MFHP-20	BMFHP-20	TGP-20
842	42 x 18½ x 11	Legger w/Cut-Out	PRO-834	RPRO-834	MFHP-52	BMFHP-52	TGP-52
845	45 x 17 x 8½	Legger	PRO-844	RPRO-844	MFHP-53	BMFHP-53	TGP-53
945	45 x 18½ x 9½	Legger w/Cut-Out	PRO-895	RPRO-895	MFHP-43	BMFHP-43	TGP-43

* Model Number Required

MFHP

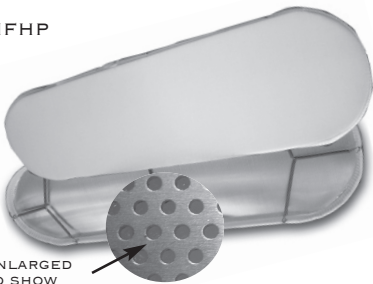

ENLARGED
TO SHOW
PERFORATION

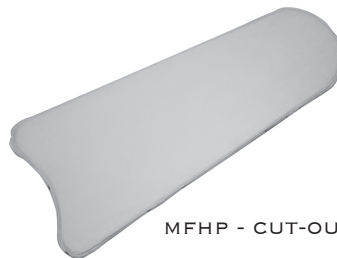

MFHP - CUT-OUT



UTILITY



PUFF IRONS COVERS AND PADS

	DESCRIPTION	PLATE NUMBERS	ARAMID W/DFN	BLACK NYLON W/DFN
#1	#1 - EGG Size #1 Cissell, Elcco, Excelsior, Hoffman, and Unipress, - (3 1/4" x 1 1/4")	Cissell #3	HTD-629	BNDB-629
#2	#2 - PEANUT or LADIES SHOULDER Size #2 Cissell, Excelsior, Hoffman, Forenta, and Unipress - (6 3/4" x 3 7/8")	Forenta - 25 PS, 33 PSVH, 33 HSV, 33-S Unipress - PI-2, PI-3 Cissell 1-L	HTD-641	BNDB-641
#3	#3 - MUSHROOM TOPPER Size #3 Cissell, Excelsior, Hoffman, Forenta, and Unipress - (12" x 7 7/8")	Forenta - 25 PS, 33 PSVH, 33 HSV, 33-S Unipress - PI-2, PI-3 Cissell #2	HTD-642	BNDB-642
#4	#4 - 14" SLEEVE Size #4 Cissell, Hoffman, and (14" x 3 5/8" x 1 3/4")	Cissell #4	HTD-643	BNDB-643
#4 1/2	#4 1/2 - 18" SLEEVE Size #4 1/2 Elcco		HTD-644	BNDB-644
#5	#5 - 22" SLEEVE Size #5 Cissell, Excelsior, and Unipress (22" x 3 7/8" x 1 1/2")	Unipress - PI-2, PI-3	HTD-630	BNDB-630
#5F	#5F - SLEEVE Forenta Part #17411 - (22" x 4 1/2" x 1 3/4")	Forenta 4-G	HTD-1210	BNDB-1210
#5FN	#5FN - SLEEVE Forenta Part #30169 - (22" x 3 7/8" x 1 1/2")	Forenta - 33 PSVH, 33 HSV, 33-S	HTD-1211	BNDB-1211
#5 1/2	#5 1/2 - 22" CURVED SLEEVE (Hogback) (22" x 3 7/8" x 1 3/4")	Cissell 4-C	HTD-671	BNDB-671
#6	#6 - MEN'S SHOULDER Cissell 1-M, Forenta, Hoffman 8, and Unipress - (7 1/2" x 4 1/2")	Cissell 1-M Ajax - PIA 16, PC 843 Unipress - PI-1	HTD-645	BNDB-645
#6F	#6F - SHOULDER Forenta Part #30170 - (7" x 4")	Forenta 7PS	HTD-1213	BNDB-1213
#7	#7 - MEN'S SHOULDER Norris-Dryco #1015 - (9 1/2" x 4 1/2")		HTD-646	BNDB-646
#8	#8 - SHOULDER Cissell 1-E and Norris-Dryco #1010 - (7 1/4" x 4 7/8")	Cissell 1-E	HTD-647	BNDB-647
#9	#9 - Vertical Sleeve Finisher	Forenta 7PS-3	1260* Cover	DB-1260* 50oz Pad

* Requires Both



#6 MEN'S SHOULDER



#2 LADIES SHOULDER
#5 1/2" HOGBACK SLEEVE



#2 LADIES SHOULDER
#3 MUSHROOM TOPPER
#5 1/2" HOGBACK SLEEVE



**PUFF IRONS
HEAD COVERS**

DESCRIPTION	INDEX NUMBER
#2 Shoulder	1084
#3 Mushroom	1091
#5 Sleever	1086
#6 Shoulder	1084
Cissell Mushroom	1091
Cissell Shoulder	1084
Cissell Sleever	1086
Cissell Curved Sleever	1085
Excelsior Mushroom	1068
Excelsior Shoulder	1067
Excelsior Sleever	1086
Forenta Mushroom	1068
Forenta Sleever	1086
Unipress Shoulder	1251
Unipress Mushroom	1252
Unipress Sleever	1253

Head covers are installed over existing frame.



HEAD COVERS

ARAMID PUFFER POST COVER



9" x 7"
ARAMID COVER

DESCRIPTION	INDEX NUMBER
9" x 7" Aramid Cover w/Velcro	ALH-9X7

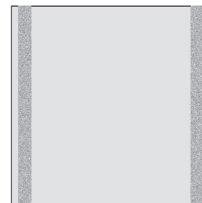

9" x 9"
ARAMID COVER

DESCRIPTION	INDEX NUMBER
9" x 9" Aramid Cover w/Velcro	ALH-9X9



**RIMAR
BUCK PADS AND HEAD PLATES**

MFG. MODEL NUMBER	BUCK SIZE	DESCRIPTION	BUCK PADS		HEAD PLATES		TEFLON GRID PLATE*
			PRO FINISH PAD/COVER		MASTER FINISH HEAD PLATE		
			TAN	RED	WHITE	BLACK	
80-L	43 ¹ / ₂ x 17 ¹ / ₂ x 11	Legger w/Cut-Out	PRO-837	RPRO-837	MFHP-31	BMFHP-31	TGP-31
80-M	19 x 9	Mushroom	PRO-690	RPRO-690	MFHP-116	BMFHP-116	TGP-116
80-U	42 x 12 x 9	Utility	PRO-842	RPRO-842	MFHP-23	BMFHP-23	TGP-23

* Model Number Required

**ROTONDI
SHIRT TENSIONING EQUIPMENT**

MFG. MODEL NUMBER	CLAMP SIZE	DESCRIPTION	INDEX NUMBER
SR3000 WOMEN'S 11"	3 ³ / ₄ x 32 3 ¹ / ₄ x 9	Shirt Finisher Cover Buck Pad - 20 oz. Cuff Clamp Cover w/Silicone Foam Pads (4 Required) Front Blade Cover/Pad Side Vent Cover w/Foam Pads (2 Required)	2173 DB-2173 FM-1108 WAJU-1103 PK-2071
SR3000 MEN'S 14"	4 x 32 4 x 12	Cover 30 oz. Bonn-E-Blue Flannel Pad Side Clamp Cover - (2 Required) Front Clamp Cover/Pad - (2 Required) Front Blade Cover Rear Clamp Cover/Pad Cuff Clamp Cover w/Silicone Foam Pads - (4 Required)	1099 FB-1096 WA-1104 WAFB-1101 WAJU-1103 PKFB-1102 FM-1108

**SAILSTAR
COVERS AND PADS FOR STEAM AIR FINISHERS**

MFG. MODEL NUMBER	CLAMP SIZE	DESCRIPTION	INDEX NUMBER
SFF20	4 x 36 4 x 26	Steam Air Finisher Cover Front Clamp Cover/Pad Rear Clamp Cover/Pad	943 956 927



**SANKOSHA
EQUIPMENT**



DF-550U



WF-740

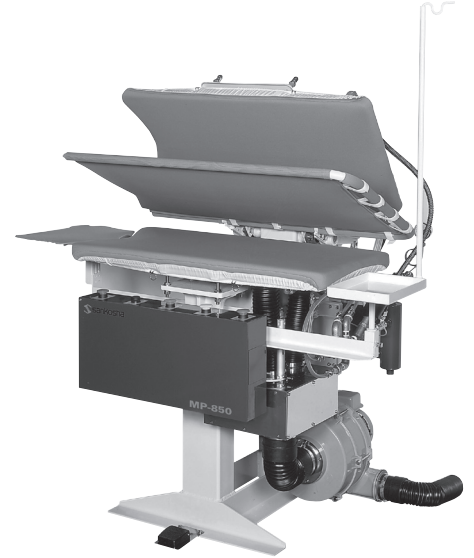

MP-850

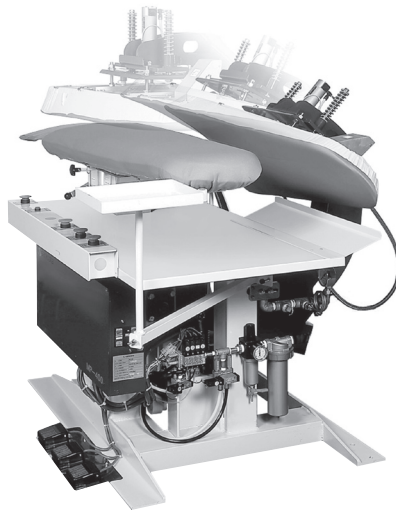

MP-450

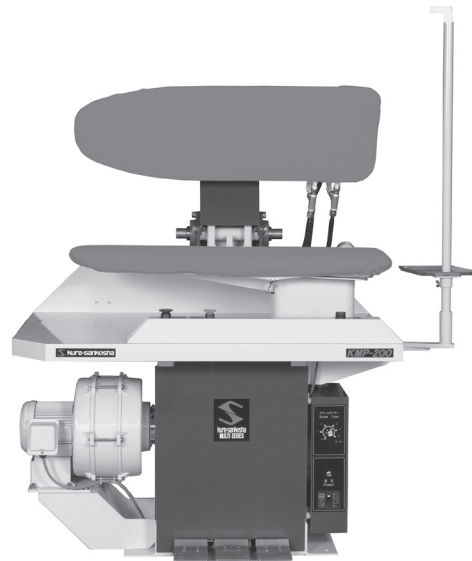

KMP-200



SANKOSHA BUCK PADS AND HEAD PAD/COVER

MFG. MODEL NUMBER	DESCRIPTION	BUCK PADS	HEAD PLATES	
		PRO FINISH PAD/COVER	SOFT HEAD PAD/COVER	MASTER FINISH HEAD PLATE
DP-150-RU DP-155-RU KMP-150	Legger	SAN-1870	SAN-1847	MFHP-1847
KMP-200	Utility (36")	SAN-1890	SAN-1849	N/A
DP-250-RU DP-255-RU KMP-250	Utility (42")	SAN-1840	SAN-1839	MFHP-1839
DP-420	Utility (45")	SAN-845	SAN-17	MFHP-17
DP-445-RU	Utility (45")	SAN-845	SAN-17	MFHP-17
DP-446-U	Legger	SAN-850	SAN-2558	MFHP-2558
DP/MP-450 MP-550	Fast Back Utility Utility	SAN-1830	SAN-1804	MFHP-1804
DP-610	Legger	SAN-1870	SAN-1847	MFHP-1847
MP-850	Double Legger	SET-1850*	HEAD COVER/PAD INCLUDED IN SET	
MP-860	Double Legger	SET-1860*	HEAD COVER/PAD INCLUDED IN SET	
DP-870-U	Double Legger	SET-1871*	HEAD COVER/PAD INCLUDED IN SET	

*Set includes Top, Bottom, Center Leaf, Pants Rest and Bar Cover

SANKOSHA TENSIONING EQUIPMENT

MFG. MODEL NUMBER	CLAMP SIZE	DESCRIPTION	INDEX NUMBER
DF550U Multi-Tensioning Garment Finisher	3 1/2 x 11	Cover	WA-2196
		Pad (20 oz.)	DB-2196
DF-550-E	4 1/2 x 32 4 1/2 x 32	Tail Clamp Cover	WA-2197
		Shoulder Expander Cover (2 Required)	WA-2198
		Shoulder Expander Pad (2 Required)	DB-2198
		Collar Support	2199
		Left Expander Cover/Pad	WAFM-2200
KF-550-U		Right Expander Cover/Pad	WAFM-2202
		Front Clamp Cover	WA-2201
		Front Clamp Foam Pad	FM-2201
		Tuck Clamp Covers (4 Required)	2203

DRY CLEANING



SANKOSHA FORM FINISHER

MFG. MODEL NUMBER	CLAMP SIZE	DESCRIPTION	INDEX NUMBER
CN-50	6 ½ X 13 6 ½ X 13	Upper Body Cover	2509
		Shoulder Covers (2 Required)	2512
		Lower Bag Assembly	1970
		Front Clamp Cover	1962
		Rear Clamp Cover	1966
		Inside Cover/Pads	SET-1968
WF-50	6 ½ X 13 6 ½ X 13	Upper Cover	1959
		Lower Bag Assembly	1970
		Front Clamp Cover/Pad	1962
		Rear Clamp Cover/Pad	1966
		Inside Cover/Foam Pads (Set of 6)	SET-1968
DF-50	6 ½ X 14 5 X 8	Upper Cover	2280
		Lower Bag Assembly	2287
		Front/Rear Clamp Covers (Requires 2)	2290
		Side Clamp Covers (Requires 2)	2283
DF100UV2 DF100UV ROTARY JACKET FORMER	8 X 15 6 X 15	Upper Cover	2525
		Lower Bag Assembly	2495
		Front Clamp Cover	2522
		Front Clamp Foam Pad	2523
		Rear Clamp Cover	2526
		Rear Clamp Foam Pad	2527
		Side Clamp Cover (Requires 2)	2528
		Side Clamp Foam Pads (Requires 2)	2529
		Side Vent Clamp Cover (Set/2)	SET-2530
		Side Vent Clamp Holder Cover (Set/2)	SET-2531
		Side Vent Pads (Requires 4)	2532
MF250 MULTI- FORM FINISHER		Cover	2599
		Front Clamp Receiver Pad	FB-2648
		Rear Clamp Receiver Pad	DB-2650
		Front Clamp Cover	WA-2652
		Front Clamp Pad	DB-2654
		Rear Tail Clamp Cover/Pad	WADB-2656
		Cuff Cover (Upper/Lower - Requires 4)	2658
		Cuff Silicone Foam Pad (Upper/Lower - Requires 4)	FM-2649
		Middle Cuff Cover (Requires 2)	2660
		Side Clamp Cover (Requires 2)	2651
		Neck Clamp Cover	2653
		Neck Clamp Silicone	FM-2655
		Upper Short Sleeve Cover (Requires 2)	2662
		Lower Short Sleeve Cover (Requires 2)	2661



**SANKOSHA
FORM FINISHER**

MFG. MODEL NUMBER	CLAMP SIZE	DESCRIPTION	INDEX NUMBER
MF250UV2 MULTI-FORM FINISHER		Cover	2680
		Front Clamp Receiver Pad	FB-2648
		Rear Clamp Receiver Pad	DB-2650
		Front Clamp Cover	WA-2652
		Front Clamp Pad	DB-2654
		Rear Tail Clamp Cover/Pad	WADB-2656
		Cuff Cover (Upper/Lower - Requires 4)	2658
		Cuff Silicone Foam Pad (Upper/Lower - Requires 4)	FM-2649
		Middle Cuff Cover (Requires 2)	2660
		Side Clamp Cover (Requires 2)	2651
		Neck Clamp Cover	2653
		Neck Clamp Silicone	FM-2655
		Upper Short Sleeve Cover (Requires 2)	2662
		Lower Short Sleeve Cover (Requires 2)	2661

DRY CLEANING



SANKOSHA COVERS AND PADS FOR PANTS TOPPERS

MFG. MODEL NUMBER	CLAMP SIZE	DESCRIPTION	INDEX NUMBER
WT-700	13 x 6	Cover & Pad Combo w/Open Cell Foam Pad	1750
WF-720		Cover Only	1732
WF-740		Open Cell Foam Pad Only	1533
		Clamp Cover/Pad (Req 2)	1749
		Cuff Clamps Cover 6" (Req 2)	2372
		Cuff Clamps Cover 10" (Req 2)	2368
DF-740 DF-740 V2	14 1/2 x 5 1/2	Cover & Pad Combo w/Open Cell Foam Pad	1885
		Cover Only	1812
		Open Cell Foam Pad Only	1876
		Clamp Cover/Pad (Req 2)	1477
		Pant Cuff Clamp Cover (Req 2) - 6"	2372
		Pant Cuff Clamp Cover (Req 2) - 10"	2368

SIDI/PONY/CAMPTEL BUCK PADS AND HEAD PLATES

MFG. MODEL NUMBER	BUCK SIZE	DESCRIPTION	BUCK PADS		HEAD PLATES		TEFLON GRID PLATE
			PRO FINISH PAD/COVER		MASTER FINISH HEAD PLATE		
			TAN	RED	WHITE	BLACK	
LEgger	47 x 19 x 1	Legger w/Cut-Out	PRO-1275	RPRO-1275	MFHP-156	BMFHP-156	N/A
UTILITY	48 x 16 1/4 x 10	Utility	PRO-1225	RPRO-1225	MFHP-148	BMFHP-148	N/A

SIDI TENSIONING PANT TOPPER

MFG. MODEL NUMBER	DESCRIPTION	INDEX NUMBER
SMB	Cover/Pad Combo	2380

* Requires 2



STIRMATIC BUCK PADS AND HEAD PLATES

MFG. MODEL NUMBER	BUCK SIZE	DESCRIPTION	BUCK PADS		HEAD PLATES		TEFLON GRID PLATE*
			PRO FINISH PAD/COVER		MASTER FINISH HEAD PLATE		
			TAN	RED	WHITE	BLACK	
CM-280-S	46 x 13 ³ / ₄ x 10	Utility	PRO-883	RPRO-883	MFHP-129	BMFHP-129	TGP-129
CML-280-S CML-400	45 ¹ / ₄ x 17 x 13 ¹ / ₂	Legger w/ Cut-Out/Square End	PRO-899	RPRO-899	MFHP-163	BMFHP-163	TGP-163
CM-282-S CM-401-282-S	45 ¹ / ₂ x 17 x 10	Utility/Legger w/ Cut-Out/Round End	PRO-1276	RPRO-1276	MFHP-159	BMFHP-159	TGP-159
PAG	45 ¹ / ₂ x 17 x 13 ¹ / ₂	Legger w/Cut-Out/ Square End	PRO-899	RPRO-899	MFHP-163	BMFHP-163	TGP-163
PAGS	45 ¹ / ₂ x 17 x 10	Utility/Legger w/ Cut-Out/Round End	PRO-1276	RPRO-1276	MFHP-159	BMFHP-159	TGP-159
PAGSL	45 ¹ / ₂ x 17 x 10	Utility/Legger w/ Cut-Out/Round End	SEE PAGE DC 43				
PAUL	46 x 13 ³ / ₄ x 10	Utility	SEE PAGE DC 43				
PAU PG	46 x 13 ³ / ₄ x 10	Utility	PRO-883	RPRO-883	MFHP-129	BMFHP-129	TGP-129

* Model Number Required

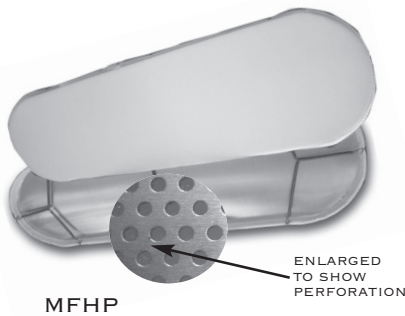

DRY CLEANING



STIRMATIC/SUPERMATIC COVERS AND PADS FOR STEAM AIR FINISHERS

MFG. MODEL NUMBER	CLAMP SIZE	DESCRIPTION	INDEX NUMBER
CM-120	4 x 39	Steam Air Finisher Cover	1279
ME2		Front Clamp Cover/Pad	1205
FF-200			

SUPERMATIC BUCK PADS AND HEAD PLATES

MFG. MODEL NUMBER	BUCK SIZE	DESCRIPTION	BUCK PADS		HEAD PLATES		TEFLON GRID PLATE
			PRO FINISH PAD/COVER		MASTER FINISH HEAD PLATE		
			TAN	RED	WHITE	BLACK	
UP-46 UPS-46	47 x 15 x 9	Utility	PRO-1258	RPRO-1258	Template Required*		

* For template instructions, see our customer service section.

TREVIL SWEATER BOARD

MFG. MODEL NUMBER	SIZE	DESCRIPTION	INDEX NUMBER
3155	36 x 72	Cover 20 oz. Pad	PK-2090 DB-2090



TREVIL TENSIONING EQUIPMENT

MFG. MODEL NUMBER	CLAMP SIZE	DESCRIPTION	INDEX NUMBER
5029 PRINCESS ULTRA FORM FINISHER	5 x 40	Cover Skirt Collar Support Front Clamp Cover Rear Inner Clamp Cover w/ reflective tape Cuff Clamp Cover (Requires 4) Rear Cover/Pad Inner Side Clamp w/silicone pad (Requires 2) Outer Clamp Cover/Pad	2022 BN-2026 PK-2021 WA-2024 WA-2028 PK-2023 PKDB-2029 PKFM-2030 PKDB-2027
5100 FORM FINISHER	12 1/2 x 6 1/2	Top Cover Lower Cover Clamp Cover w/Pad (Requires 2)	2330 2320 PKDB-2333
5122 FORM FINISHER	11 3/4 x 5	Upper Cover Lower Bag Assembly Front/Rear Clamp Cover/Pad (Requires 2) Collar Clamp Cover/Pad	2369 2365 2347 2367
5302 PANT TOPPER	12 x 5	Cover and Pad for Pant Topper Clamp Cover w/Pad (Requires 2) Fly Clamp/Pad	2190 PKFM-2193 PKFM-2195
5304 PANT TOPPER	8 3/4 x 8	Clamp Cover/Pad (Requires 2) Fly Cover	PKD-1975 PK-1988



UNIPRESS
EQUIPMENT

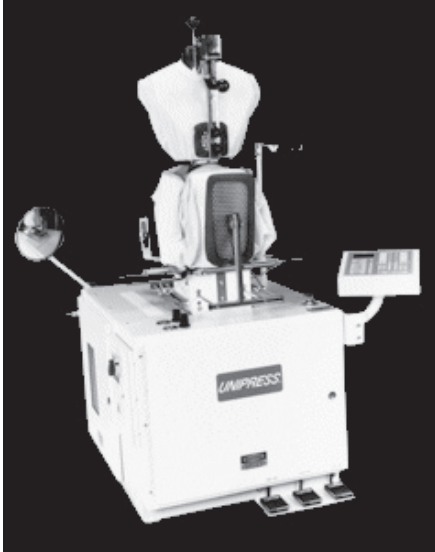

TUF



VERSAFORM PLUS - V3

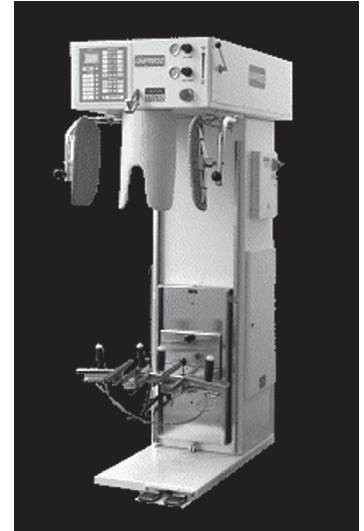

TFP-P



46-X



STF

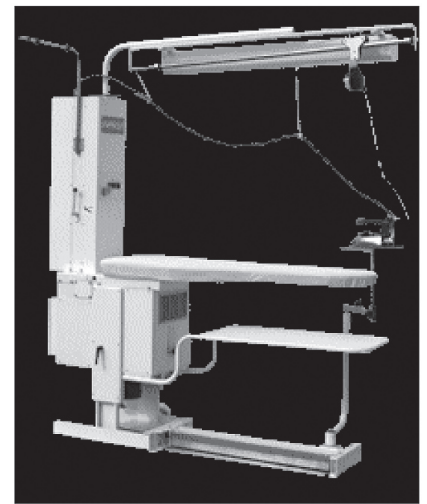

AFB



UNIPRESS BUCK PADS AND HEAD PLATES

MFG. MODEL NUMBER	BUCK SIZE	DESCRIPTION	PRO FINISH PAD/COVER		MASTER FINISH HEAD PLATE		TEFLON GRID PLATE*
			TAN	RED	WHITE	BLACK	
19MX	19 x 9	Mushroom	PRO-818	RPRO-818	MFHP-3	BMFHP-3	TGP-3
DM-19	19 x 9	Mushroom	PRO-819	RPRO-819	MFHP-131	BMFHP-131	TGP-131
SDU-19-M	19 x 9	Mushroom	PRO-818	RPRO-818	MFHP-3	BMFHP-3	TGP-3
DT-20 DT-21	21 ¹ / ₄ x 9 x 8	Topper	PRO-820	RPRO-820	MFHP-8	BMFHP-8	TGP-8
42X 42Y DU-42 GBU-42 SDU-42 UL-42-O DL-45	42 x 12 x 9	Utility	PRO-842	RPRO-842	MFHP-78	BMFHP-78	TGP-78
DLA-45	45 x 19 ¹ / ₂ x 10	Legger w/Cut-Out	PRO-855	RPRO-855	MFHP-79	BMFHP-79	TGP-79
DLA-45	45 x 19 ¹ / ₂ x 10	Legger w/Cut-Out	PRO-855	RPRO-855	MFHP-73	BMFHP-73	TGP-73
45X 45LX 45Y DU-45 GBU-45 SDU-45	45 x 12 x 9	Utility	PRO-845	RPRO-845	MFHP-111	BMFHP-111	TGP-111
46X 46Y GBL-46 SDL-46	46 x 18 x 9 ¹ / ₂	Legger w/Cut-Out	PRO-850	RPRO-850	MFHP-153	BMFHP-153	TGP-153
DL-46 DLA-46	46 x 19 x 8 ¹ / ₂	Legger w/Cut-Out	PRO-850	RPRO-850	MFHP-95	BMFHP-95	TGP-95
DOC-47	47 x 16 x 9	Offset - Utility	SEE PAGE DC 44				
DC-46S	46 X 18 X 9 1/2	Legger w/Cut-Out	PRO-850	RPRO-850	RMFHP-2048	BMFHP-2048	TGP-2048
Center Leaf: ROWN-2370							

* Model Number Required



**UNIPRESS
HOT HEADS AND SILK PRESSES**

MFG. MODEL NUMBER	BUCK SIZE	DESCRIPTION	
42XH 42YH GBH-42 SDH-42	42 x 12 x 9	Utility - Silk	SEE PAGE DC 43
45HOX	45 x 12 x 9	Utility	SEE PAGE DC 43
46XH	46 x 18 x 9 1/2	Utility	SEE PAGE DC 43

**UNIPRESS
COVERS AND PADS FOR PANTS TOPPERS**

MFG. MODEL NUMBER	CLAMP SIZE	DESCRIPTION	INDEX NUMBER
ATA	11 x 3 3/4	Cover Only for Pants Topper - 40587	992
		Foam Pad	1203
		Fly Clamp Cover	C-1034
		TEXSTEEL Steel Base Pad (Diffuser)	TS-1203
		FLAN-O-WOOL Metal Flannel Pad	
ATF		Cover & Pad Set for Pants Topper	1554
		Cover Only for Pants Topper	1254
		Foam Pad	1403
		TEXSTEEL Steel Base Pad (Diffuser)	TS-1403
		FLAN-O-WOOL Metal Flannel Pad	
ATT	18 1/4 x 9	Red Cover & Pad Set for Pants Topper	2100
		Clamp Cover/Pad (2 Required)	WKFM-2099
		Red Fly Clamp Cover	ROWN-1746
		Skirt	2116
MTF STF	18 1/2 x 9	Cover & Pad Set for Pants Topper	1584
		Cover Only for Pants Topper	1450
		Foam Pad	1447
		Fly Clamp Cover/Pad	B-1746
		Clamp Cover/Pad (2 Required)	CPDB-1445



STF



UNIPRESS

COVERS AND PADS FOR AIR STEAM FINISHERS

MFG. MODEL NUMBER	CLAMP SIZE	DESCRIPTION	INDEX NUMBER
ASF	4 x 36	Steam Air Finisher Cover - 22858	1094
		Net Overbag - 22857	947
		Terry Cloth Stain Guard - 22882	1402
		Front Clamp Cover/Pad	956

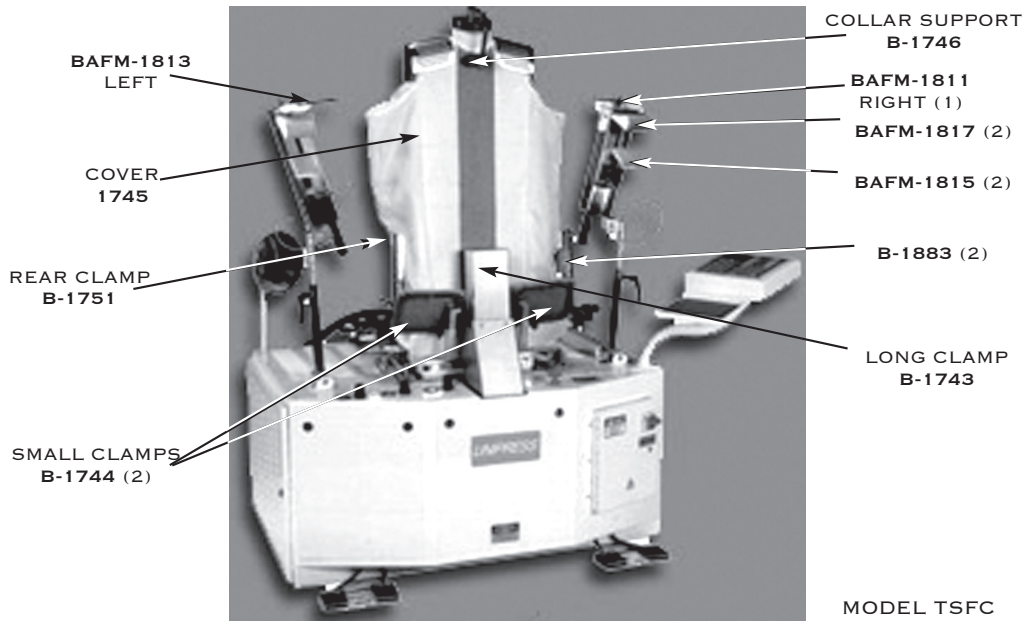



**UNIPRESS
TENSIONING EQUIPMENT**

MFG. MODEL NUMBER	CLAMP SIZE	DESCRIPTION	INDEX NUMBER
TPF PANTS FINISHER		Front Plate Cover	B-1747
		Rear Plate Cover	B-1748
		Waist Clamp Cover	B-1746
TPF-P PANTS FINISHER	10x18 x14	Pant Topper Cover w/Foam	1760
		Clamp Cover/Pad (2 Required)	WKFM-1759
		Rear Expander Cover (3" x 8" — older)	WK-1762
		(5" x 8" — newer)	or WK-1819
		Waist Clamp Cover	B-1746
TSF VERSAFORM FINISHER	4 1/2 x 33 1/2 6 1/2 x 8 5/8	Shirt Finisher Cover	1745
		Collar Clamp Cover	B-1746
		Clamp Cover (Long)	B-1743
		Clamp Cover (Small) (2 Required)	B-1744
		Rear Blade Cover	B-1751
		Side Clamp Cover (2 Required)	B-1883
		Cover for Rear Bottom Plate (Optional)	B-1841
TSFC VERSAFORM FINISHER	4 1/2 x 33 1/2 6 1/2 x 8 5/8	Shirt Finisher Cover	1745
		Collar Clamp Cover	B-1746
		Clamp Cover (Long)	B-1743
		Clamp Cover (Small) - (2 Required)	B-1744
		Rear Blade Cover	B-1751
		Side Clamp Cover (2 Required)	B-1883
		Cuff Clamps, as follows:	
		Upper Right Cover/Pad (1 Required)	BAFM-1811
		Upper Left Cover/Pad (1 Required)	BAFM-1813
		Lower Clamp Cover/Pad (2 Required)	BAFM-1815
Cuff Holder Cover/Pad (2 Required)	BAFM-1817		
TUF UTILITY FINISHER	4 x 4 6 1/4 x 11 1/4	Upper Cover	1755
		Front Clamp Cover	1756
		Lower Air Bag Cover	1757
		Front/Rear Clamp Cover (2 Required)	1758
TUFR UTILITY FINISHER		Cover	1755
		Front Collar Clamp	1756
		Front/Rear Clamp Cover/Pad (2 Required)	2688
		Vent Clamp Cover/Pad (2 Required)	2685
		Lower Air Bag Cover	2690
V3 VERSAFORM PLUS FINISHER	5 x 32 5 x 40 1/2 6 x 29 1/4	Finisher Airbag Cover	2220
		Skirt	BN-2216
		Cover Flank - Fixed (2 Required)	WA-2208
		Cover/Pad Flank - Moveable (2 Required)	WAFM-2209
		Rear Clamp Cover - Fixed	WA-2211
		Rear Clamp Cover/Pad - Moveable	WAFM-2213
		Cuff Cover/Pad (4 Required)	2214
		Silicone Cuff Pad (2 Required)	RS-2215
		Front Clamp Cover - Moveable	ROWN-2217
		Front Clamp Cover - Moveable	ROWN-2218
		Front Clamp Cover/Pad	2219
		Collar Support Clamp Cover	ROWN-1756
		Fly Clamp Cover	ROWN-1746

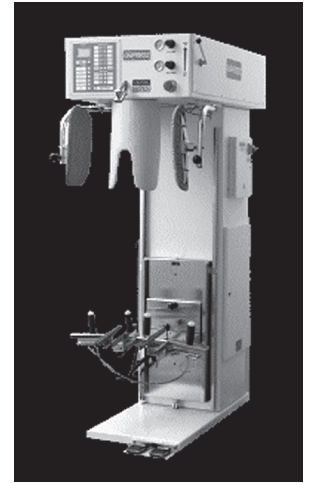

TPF-P

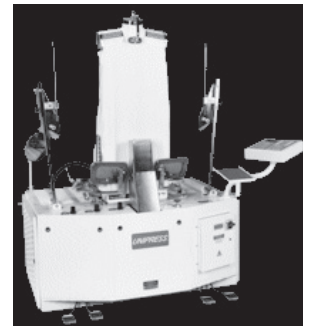

SP VERSAFORM



TUF



**UNIPRESS
TENSIONING EQUIPMENT**

MFG. MODEL NUMBER	CLAMP SIZE	DESCRIPTION	INDEX NUMBER
V4		Finisher Airbag Cover	2220
VERSAFORM		Skirt	BN-2216
PLUS		Cover Flank - Fixed (2 Required) Cover/	WA-2208
FINISHER		Pad Flank - Moveable (2 Required) Rear	WAFM-2209
		Clamp Cover - Fixed	WA-2211
		Rear Clamp Cover/Pad - Moveable	WAFM-2213
		Lower Clamp Cover (2 Required)	2704
		Cuff Holder Cover (2 Required)	2073
		Cover - Upper	3324
		Front Clamp Cover - Moveable	ROWN-2217
		Front Clamp Cover/Pad	2219
		Collar Support Clamp Cover	ROWN-1756
		Fly Clamp Cover	WKFM-1746



**VAPORPRESS
BUCK PADS AND HEAD PLATES**

MFG. MODEL NUMBER	BUCK SIZE	DESCRIPTION	BUCK PADS		HEAD PLATES		TEFLON GRID PLATE*
			PRO FINISH PAD/COVER		MASTER FINISH HEAD PLATE		
			TAN	RED	WHITE	BLACK	
MTVP-451	47 x 14 x 9½	Utility	PRO-1225	RPRO-1225	MFHP-138	BMFHP-138	TGP-138
MTVP-453	45 x 18 x 12½	Legger w/Cut-Out	PRO-1224	RPRO-1224	MFHP-139	BMFHP-139	TGP-139
MTVP-453	46 x 21 x 10	Utility/Legger w/Cut-Out	PRO-1257	RPRO-1257	MFHP-157	BMFHP-157	TGP-157

* Model Number Required

**VEIT
COVERS AND PADS FOR PANT TOPPERS**

MFG. MODEL NUMBER	DESCRIPTION	INDEX NUMBER
1874	Front Cover	2237
8730	Rear Cover	2239
8740	Waist Clamp Cover	PK-2240
	Skirt (Requires 2)	PF-2041



**VEIT
FORM FINISHERS**

MFG. MODEL NUMBER	CLAMP SIZE	DESCRIPTION	INDEX NUMBER
8345 SHIRT TENSIONER	4 x 32	Cover 30 oz Flannel Pad Side Clamp Cover (Requires 2) Front Clamp Cover/Pad (Requires 2) Front Blade Cover Rear Clamp Cover/Pad Cuff Clamp Cover w/Silicone Foams Pad (Requires 4)	1099 FB-1096 WA-1104 WAFB-1101 WAJU-1103 PKFB-1102 FM-1108
8346 SHIRT TENSIONER		Cover 20 oz Flannel Pad	2601 DB-2602
8360 MULTIFORM FINISHER		Cover	PK-2080
8362 MULTIFORM FINISHER		Cover Cover – Lateral (Requires 2) Silicone Side Clamps (Requires 2) Front/Back Cover (Requires 2) Waist Band Stubble Cover (Requires 2) Lapel Clamp Cover Silicone Front/Back (Requires 2) Clamp Stubble Cover Foam Suction Silicone (Requires 2)	2410 WA-2412 FM-2411 WA-2416 2414 WK-2415 FM-2418 2417 FM-2413